

**yes,
we
can!**

2

 Richmond

Ciclo 1

Lengua extranjera. Inglés

Teacher's Guide



Av. Río Mixcoac No. 274, Col. Acacias,
Alcaldía Benito Juárez, C.P. 03240, Ciudad de México

Yes, We Can! Teachers Guide Level 2
© Text: Diane Hermanson, Dominic Wright

Publisher: Justine Piekarowicz
Project Manager: Griselda Cacho
Editor: Paola Guerrero, Daniel Velázquez
Design: Celia Alejos, Orlando Llanas, Jaime Angeles, Daniel Santillán
Cover Design: Orlando Llanas
Technical Coordination: Daniel Santillán
Technical Assistance: Susana Alcántara

Illustrations: Erick Arellano pp. 7, 13, 14, 15, 101, 103; Ezequiel Dominguez pp. 4, 5, 6, 8, 9, 16, 17, 74;
Hugo Miranda pp. 53, 55, 60; Guillermo Graco pp. 20, 23, 105; David Peón pp. 61, 65; Gerardo
Sanchez pp. 33, 89, 107; Edgardo Solas pp. 64, 65; Ismael Vázquez pp. 36, 38, 39, 40, 44, 68, 74, 76,
77, 79, 80, 81, 84, 85, 86, 87, 88, 89.

Photographs: ©Shutterstock.com pp. 34 the prado gallery (trabantos / Shutterstock.com), Metro line
B San Lazaro station (tateyama / Shutterstock.com), young girls in an all girls team in Woodbridge
(barbsimages / Shutterstock.com).

Images used under license from ©Shutterstock.com

Richmond publications may contain links to third party websites or apps. We have no control over
the content of these websites or apps, which may change frequently, and we are not responsible
for the content or the way it may be used with our materials. Teachers and students are advised to
exercise discretion when accessing the links.

All rights reserved. No part of this book may be reproduced, stored in a retrieval system or
transmitted in any form or by any means, electronic, mechanical, photocopying, recording
or otherwise, without prior permission in writing from the Publisher.
The Publisher has made every effort to trace the owner of copyright material; however,
the Publisher will correct any involuntary omission at the earliest opportunity.

First Edition: 2018
First Reprint: July 2019
ISBN: 978-607-06-1545-0

D.R. © Richmond Publishing, S.A. de C.V., 2018
Av. Río Mixcoac No. 274, Col. Acacias,
Alcaldía Benito Juárez, C.P. 03240, Ciudad de México

Miembro de la CANIEM
Registro No. 3249

Printed in Mexico by Impresora Tauro, S.A. de C.V.
Av. Año de Juárez 343, col. Granjas San Antonio,
Iztapalapa, c.p. 09070, Ciudad de México

Programa Nacional de Inglés.
Para alumnos en Educación Básica. PRONI

La producción de estos materiales fue hecha por encargo de la Secretaría
de Educación Pública para usarse como material didáctico
en escuelas públicas de Educación Básica.

Impreso en México · Printed in Mexico
Distribución gratuita · Prohibida su venta

Unit 4

Let's Make Signs!

Curricular Objectives

- (A) Exchanges associated with media.
- (B) Produce signs for public spaces.

Environment Family and community

Final Product Own Signs

Big Book Taking a Walk

Achievements

Interpret signs to follow instructions. Recognize, by their names, some of their features (for example, colors, arrows, people silhouettes, etc.). Discover purpose and intended audience of signs.

Suggested Materials paper, colored pencils

Warm Up

Greet students and ask them to stand up.

Continue giving other instructions for them to perform:

T: *Open your books. Sit down.*

Unit Overview

1 Look at the images and circle T (true) or F (false).

Students should look at the pictures. You could elicit what they are and what they mean (*Exit to the left*, *Beware of the dog* and *Swimming is prohibited*). We recommend reading the six statements and having students circle *True* or *False*. They should discuss their opinions in groups. Explain that, in general, yellow is used for signs of warning, red is used for prohibitions and blue or green is used for directions or informative signs.

► Discuss your answers with your class and teacher.

We suggest discussing and check the answers as a class. You could call on different students to share their answers and discuss with the group if they agree.

Unit 4

Let's Make Signs!

Unit Overview

Environment: Family and community

Final Product: Own Signs

Big Book: Taking a Walk

Curricular Objectives:

- (A) Exchanges associated with media.
- (B) Produce signs for public spaces.

Environment: Family and community

Final Product: Own Signs

Big Book: Taking a Walk

Achievements

Interpret signs to follow instructions. Recognize, by their names, some of their features (for example, colors, arrows, people silhouettes, etc.). Discover purpose and intended audience of signs.

Suggested Materials: paper, colored pencils

Warm Up

Greet students and ask them to stand up.

Continue giving other instructions for them to perform:

T: *Open your books. Sit down.*

Unit Overview

1 Look at the images and circle T (true) or F (false).

1



2



3



1. These images are signs.	T F
2. You can find these images at home.	T F
3. These images are important because they are fun.	T F
4. Only adults need to follow the instructions in signs.	T F
5. Sign 3 means <i>prohibition</i> .	T F
6. When signs mean <i>be careful</i> , they are yellow.	T F

► Discuss your answers with your class and teacher.

Discuss these questions with your group:

Can you interpret text in signs and follow instructions? Can you complete written instructions? Can you do your own instruction? Can you use oral instructions for others? Can others understand your instructions?

How Much Do I Know?

We suggest that you read the questions out loud and ask students if they understand them. If necessary, translate any words they don't know. Students then decide if they can do all of the things mentioned.

Poster

We recommend using Search and Spot from the Poster Activities on page xi. You could use the activities of the woman in the poster. You could also discuss the things she is doing to protect the environment.

Wrap Up

We suggest doing a picture dictation. You can choose a couple of signs or simple picture dictate the things in the picture, one item at a time. Students should draw their pictures following your instructions.

Answers: 1. T, 2. F, 3. F, 4. F, 5. T, 6. T

P. 24

the pot. the plant Put in



P. 23

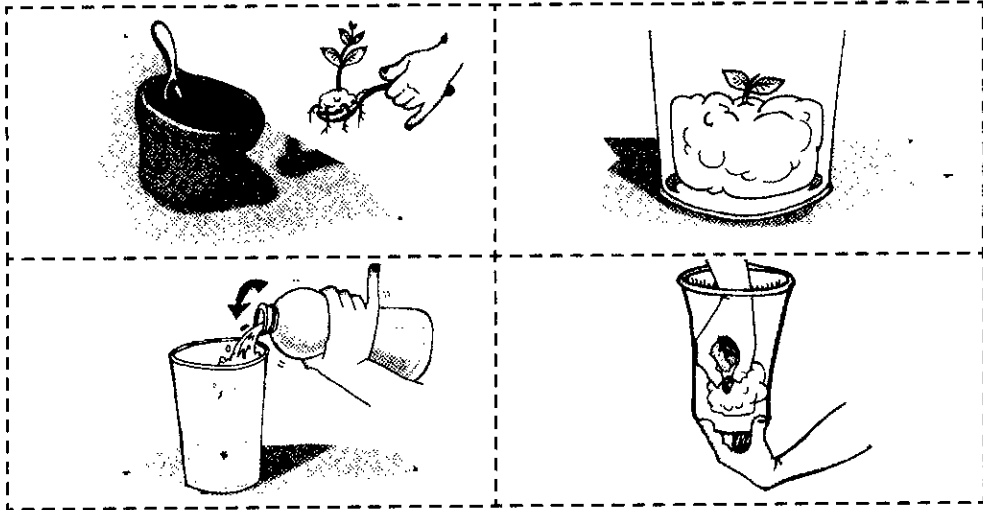

Picture Dictionary

Unit 3

Nature



water



plant



sand



seeds



soil

Materials



plastic cup



cotton



container



pot





Self-Assessment and Peer-Assessment

1 The following self-assessment and peer-assessment cards can be used to assess your students. Ask students to work in pairs. Ask students to complete the self-assessment card by choosing an emoji. Ask students to complete the peer-assessment card by choosing an emoji.

SELF-ASSESSMENT CARD

Name: _____





Date: _____

				
I can recognize instructions and materials.				
I can complete instructions.				
I can follow instructions.				
I can give instructions.				

PEER-ASSESSMENT CARD

Name: _____

Date: _____

				
My classmate can recognize instructions and materials.				
My classmate can complete instructions.				
My classmate can follow instructions.				
My classmate can give instructions.				

TERMIN 1

Product Template

Directions: Print

Complete the chart with the information you want to include in your set of instructions for your Final Product.

	DRAWING
Container: _____	
Seeds: _____	
Liquid: _____	
Other: _____	

Look at the actions you circled on page 23. Write them below. This will help you write your Final Product.

Write two instructions to do the experiment for planting a plant. This will help you practice for your Final Product.

1. _____
2. _____

Final Product

1 Present your illustrated instructions for planting a plant.



Instructions

1. Get together with your classmate to present your illustrated instructions.
2. Take out the sheet of paper you worked with on page 26.
3. Read it again to take a last revision.
4. Present your instructions to another pair of classmates.

Group Reflection

- Did you like your experiment?
- Did it go well?
- Was it easy to write the instructions?
- Did you enjoy illustrating the materials and steps?

Self-evaluation

Reflect on the following aspects of your presentation and mark (✓) your answers.

- I can write instructions for planting a plant. Yes I need practice No
- I can illustrate materials for an experiment. Yes I need practice No
- I can illustrate instructions of an experiment. Yes I need practice No

Achievements

Follow instructions. Participate in the planting of a plant. Reflection and self-evaluation.

Warm Up

You could play a game of Follow the Leader on page xiv to review instructions for planting a plant. Mime each instruction for students to copy, and then model the pronunciation for students to repeat as they continue miming.

Final Product

Remind students of the experiments they carried out throughout this unit. Ask them which of them they liked the most and why.

1 Present your illustrated instructions for planting a plant.

Instructions

1. Students work with their Final Product partner to review their illustrated instructions.

2. Students retrieve their illustrated materials and instructions that they prepared on page 26.

3. Students practice reading the instructions out loud and presenting the illustrations with their partner. They can make any last-minute revisions now if necessary.

4. Pairs take turns with another pair to present their instructions. At the end, some volunteer pairs could present their instructions to the class.

Group Reflection

Go over the questions and have students discuss in their pairs. Then ask them to share their findings with the class.

Self-evaluation

Ask students what they learned in this unit, what they liked the best and what they didn't like. Have them read the questions and mark the answers for themselves.

Evaluation

Photocopy the Evaluation Instrument: Self-Assessment and Peer-Assessment card on page T27b (1 per student) and have students complete the template according to their performances.

Wrap Up

If possible, students should continue caring for the plant that they planted on page 25. They could also plant a plant at home and report back to the class every month or so on its progress.

Achievements

Rewrite names of materials. Complete directions from their inception. Practice pronouncing words in instructions.

Suggested Materials paper, paper plate (1 per student), streamers, hole punch, yarn, scissors, glue

Warm Up

You could play a game of Action TPR on page xii to review instructions for planting a plant. Students should mime each command and then repeat it.

10 Final Product Preparation.

Students work with their partner for the Final Product to list and illustrate the materials needed for planting a plant on a sheet of paper. They should use about a third of the paper so there is room for illustrated instructions below.

11 Work with your classmate and remember the steps you followed to plant a tree or a plant on page 25. Make notes in the space below.

Students should try to do this activity from memory. They can check page 25 after they have written notes.

10 Work with your classmate from page 22. Now you have learned important information to do the tasks below.

1. Look at your **Final Product** on page 92 and see Activity 1.
2. On a separate sheet of paper, write the list of materials you chose.
3. Illustrate each material.

11 Work with your classmate and remember the steps you followed to plant a tree or a plant on page 25. Make notes in the space below.

► Use your notes and, on the same sheet of paper, write the instructions to plant a plant. Use the information you wrote in Activities 2 and 3 of the **Final Product** on page 92. Follow the suggestions below:

1. Illustrate the instructions.
2. Read your list of materials and instructions out loud and make sure everything is correct.
3. Keep this sheet of paper with you to get ready for your presentation next lesson.

26 Unit 3

► Final Product Preparation.

1. Students write and illustrate the instructions for planting a plant on the same sheet of paper on which they listed and illustrated the materials.
2. Students can read their materials out loud first to each other, then to another pair, and finally to the class to check that everything is correct.
3. Students keep their sheets of paper in their portfolio.

Wrap Up

We recommend playing the game Choose an Item from the Poster Activities on page xi.

How Am I Doing?

So far you know different materials and instructions. Read the sentences and circle the answer.

- I know the materials I need for planting a plant. Yes. I need to study. No
- I know some ways to write instructions for planting a plant. Yes. I need to study. No
- I can illustrate the steps for planting a plant. Yes. I need to study. No

Work in groups and follow the instructions.

Suggested Materials

- plant (tree)
- soil
- watering can
- a small shovel

1. Choose a tree or plant.
2. Get a place (ask for permission).
3. Dig a hole as deep as the root ball and twice as wide.
4. Remove the container.
5. Place the tree plant in the hole. Fill in around with soil and pack the soil with your hands.
6. Make a little dam around.
7. Water the tree plant.
8. Name your tree plant.

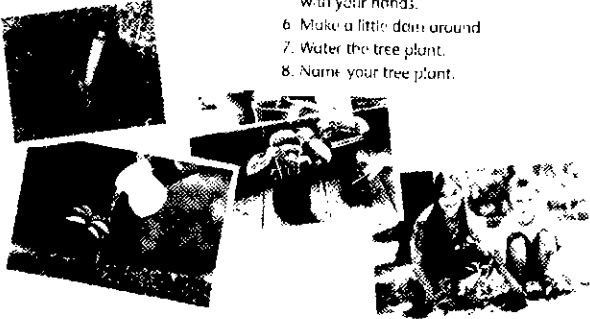

Discuss the questions.

1. Was it easy to follow the instructions of the experiment?
2. Was it easy to plant the tree or plant you chose?
3. Did you like doing it?

Unit 3 25

Achievements

Follow instructions to perform an experiment.

Suggested Materials Nonfiction Big Book, seedlings, soil, watering can, small shovel

Warm Up

Students could share their previous experiences of planting seeds and growing plants: type of plants, care, success, and so on.

How Am I Doing?

You could go through the statements as a class, eliciting some ideas for each one, before students mark their own performance so far. Students should be able to link each statement to an activity in the unit.

9 Work in groups and follow the instructions.

If there is a garden area at school, students can do this activity there. Otherwise, they could do it in pots. If they germinated seeds on page 23, they could use those seedlings, or seedlings could be purchased from a garden center.

Students form groups and help each other read through the instructions and plant the seedlings.

Discuss the questions.

Students should discuss the questions in their groups before reporting answers to the class.

Wrap Up

Time to read Nonfiction: A Different Way to Grow Plants. 28

Turn to Page 13 of the story. Explain to students that there are easy instructions for growing a plant using hydroponics. Draw their attention to the illustrations. Point out that illustrations make it easier to understand instructions. Play the last part of Track 28. The read the instructions again and invite students to mime the actions.

Achievements

Identify words that are part of instructions. Complete directions from their inception. Follow instructions to perform an experiment. Help students discover alternative ways of carrying out actions. Review punctuation and use of uppercase and lowercase letters.

Warm Up

Students could review how to form instructions by looking at the four pictures they glued on page 23 and reading the instruction below each one. After a while, they could cover the words and try to recall the instructions for each picture from memory.

6 Cut out and glue the instruction on Worksheet 3.

Students should cut out the four parts of the instruction in Activity 2 of Worksheet 3 and glue them in place. You may wish to check their placement of the parts before they glue.

► Final Product Preparation.

Students can color the words by themselves or this activity can be done as a class.

7 Final Product Preparation.

► Read the instructions. Then write them under the pictures.

Student should first describe what they see and what they think is happening in the pictures. You could ask volunteers to suggest possible instructions for each picture out loud before they write anything. If necessary, the scrambled instructions could also be written on the board before students write. Students should start each instruction with a capital letter and finish it with a period.

8 Final Product Preparation.

Students can choose the instructions on this page or others that describe how to plant a plant to complete the activity on Worksheet 3.



Final Product Preparation.

For more on experiments, go to:

www.sciencekids.co.nz/experiments.html

Students should access the cited website and find an interesting experiment. You could do this as a class so students all choose the same experiment before writing the materials and instructions individually, or students could choose their own experiments.

6. Cut out and glue the instruction on Worksheet 3.

► Remember that is important to write correctly. Follow the instructions below.

1. Find a word with a capital letter. Color the word red.
2. Find a question mark. Color it blue.
3. Find the subject of the question. Color it green.
4. Color the actions yellow.

7 Look at the pictures and write an instruction. Remember to use capital letters. This will help you practice your writing.



6 Join your classmate from page 22. Go to the www.sciencekids.co.nz/experiments.html on page 92 and do Activity 3.

► Go online and look at the different experiments. Choose one you like and write the materials and the instructions in your notebook.

www.sciencekids.co.nz/experiments.html

Wrap Up

You can tell your students to act out the steps on page 24. You could also ask them to act out another set of instructions they know.

Answers: 6. Put the plant in the pot. ► 1. Put (red) 2. Period (blue) 3. Put (blue) 7 Pour a little water in the container. Put the seeds in the soil in the container.

4 Look and label the materials for the experiment.

Seed Experiment



• Cut out and glue the pictures on Worksheet 3.

Instructions:



1. Put a seed in the cotton ball. Put it in the plastic cup.

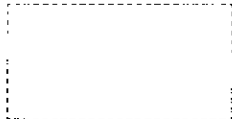

2. Pour a little water in the cup.



3. Watch it grow.



4. Put the plant in the pot.

► Answer the questions.

1. Can you use a jar for the experiment, too?
2. How many seeds do you think you can put in the cotton ball?
3. How many days do you think it takes a plant to grow?

► Read the instructions and circle the verbs in the sentences to do the experiment.

► Get together with your pair from page 22. Go to the ... on page 92 and complete Activity 2.

Achievements

Identify words that are part of instructions. Identify and rewrite names of materials Practice pronouncing words in instructions. Review punctuation and use of uppercase and lowercase letters.

Suggested Materials Nonfiction Big Book, cotton wool, seeds, plastic cups, water

Warm Up

To review the stages of planting a seed, you could write the first three stages of the instructions on page 23 in random order for students to read and number in the correct order.

4 Look and label the materials for the experiment.

In this class, students will see how a seed can first germinate in cotton wool before being planted in soil. Students can refer to the Picture Dictionary on page 85 to label the materials.

► Cut out and glue the pictures on Worksheet 3.



Students should first cut out the four pictures on Worksheet 3. They can then work alone to place the pictures, without gluing them yet. You could model the pronunciation of each instruction for students to repeat and practice. Students should glue the pictures in place at the end.

► Answer the questions.

You could go through the questions as a class before students answer them in pairs. They could report their answers to the class at the end.

► Read the instructions and circle the verbs in the sentences to do the experiment.

Strong students could read an instruction each out loud. Review with the class what a verb is. Students can then circle the verbs in the instructions. You may wish to point out that "plant" in instruction 4 is a noun, but that the same word can also be used as a verb. Students can then circle the verbs in the instructions. They should also be able to say why the verb at the start of each instruction has a capital letter: it's the first word in a sentence.

5 Final Product Preparation.

We suggest reading through the instructions as a class. With their Final Product partner, students can then copy the verbs they circled to Activity 2 on the Product Template. You could point out that these verbs will be useful when it comes to writing instructions for planting a plant in the Final Product. If possible, students could follow the instructions to plant some seeds in cotton wool in preparation for planting seedlings on page 25.

Wrap Up

Time to read Nonfiction: A Different Way to Grow Plants 28

Display page 28 of the Big Book and ask a volunteer to read the title. Read pages 13 to 20, line by line, and have students repeat after you. Play Track 28 again. Then ask a few comprehension questions: Does hydroponics use soil to grow plants? A: No, it uses water. Is hydroponics a new method? A: No, it isn't. Who used this method many years ago? A: The Aztecs. What do plants need to grow? A: They need water, sunlight outdoors or light indoors, nutrients, air.

Answers 4 seeds, cup, water, cotton, soil, pot, ► 1. Yes, to germinate the seed, but probably not to grow it after as it doesn't have holes in the bottom and the seed may become waterlogged. ► 1. Put, Put, 2. Pour, 3. Watch (and grow, but it is not an imperative), 4. Put

Topic 1

Achievements

Anticipate content from previous knowledge, title and illustrations. Differentiate instructions of list of materials. Rewrite names of materials.

Suggested Materials celery and pieces of paper from previous class, colored pencils

Warm Up

Show the celery to the class and remind students of the experiment. Students should say if they predicted what would happen in the celery experiment correctly. They could also try to explain the results: plants draw water up their stems and into their leaves, which is why the celery leaves turn red or pink. Allow them to draw the results on their sheet of paper at the end.

2 Look and circle the materials you can use for growing a plant.

Students can look up some of the words for materials in the Picture Dictionary on page 85. They should explain what the other words mean using the pictures for help. Then they should work alone to circle materials that can be used to grow a plant.

► Compare your answers with a classmate.

Students should work with a partner to compare which materials they circled. Any discrepancies can be reported to the class.

3 Final Product Preparation.

Students will work in pairs on their Final Product. They can choose their own partners or you could assign them. Go through the instructions with the class. Students should then choose one item from each group and complete the first activity on the Product Template with its name and a sketch.

Wrap Up

Students could act out growing a plant from seed in pairs. One student could pretend to be the seed, and the other student plants the seed, covers it in soil, puts it in a sunny place and waters it until the first student slowly grows, standing up and extending his or her arms.

2 Look and circle the materials you can use for growing a plant.

Containers

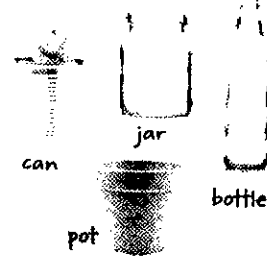

coffee beans



beans



corn



lentils



Liquid

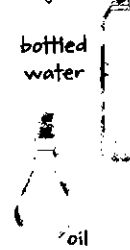

Other



cotton



flour

► Compare your answers with a classmate.



3 In this unit, you will write and illustrate instructions for planting a plant. Choose a classmate to work with then go to the Product Template on page 92 and complete Activity 1.



Answers: 3 The pot and the can may be used as containers (and possibly the jar, but a suitable container should have holes in the bottom). All the seeds except the coffee beans should work. Oil will not work as a liquid, but the others will. Soil is the best growing medium, though cotton and sand may work to germinate seeds.

1 Look and label.

Instructions Materials

Planting a Plant

Plastic cups  Seeds 

Soil  Water 

1. Put soil in the plastic cup.
2. Plant a seed in the cup with soil.
3. Add water.
4. Draw the results.

► Complete the information.

1. Title:
2. Number of materials:
3. Number of steps.

► Answer the questions.

1. What's the experiment for?
2. Do you know what happens with the seed?
3. Is the experiment easy or difficult?

Unit 3 21

Achievements

Identify parts of the text and their disposition.
Differentiate instructions of list of materials.
Recognize graphic and textual components.

Suggested Materials Nonfiction Big Book, a celery stalk, food coloring, a glass of water, a spoon, paper (1 piece per student)

Warm Up

You can ask students if they know what instructions are. Then, you can do the activity *What Is Missing?* from the *Poster Activities* on page xi.

As an added feature, you could ask your students where they have seen instructions.

Development

1 Look and label.

There are two sections to the board in the picture: at the top, there are materials needed to grow a plant. Below, there are instructions on how to use the materials. You could read through each section with the class before prompting students to label.

► Complete the information.

Students can find the information in the picture by themselves. They should write the number of types of material, and not count each seed or cup.

► Answer the questions.

Students get together in small groups to discuss the questions. You could read through the questions first to make sure everyone understands.

Answers: 1 Materials, Instructions, ► 1. Planting a Plant, 2. 4, 3. 4 ► 1. For growing a plant. 2. Answers will vary, but students should know it will grow. 3. Easy to carry out, but it may be hard to get a seed to germinate.

Poster

Display *Poster 3* and play a game of *Copy the Poster* from page xi. Students could then carry out the experiment as a class and predict what they think may happen.

Wrap Up

Time to read Nonfiction: A Different Way to Grow Plants 28

Display the *Nonfiction Big Book*. Flip through pages 13 to 20 and ask students to predict the topic.

Go to page 13 and read the title.

Play *Track 28* and have students listen as you point to some images on each page.

Finally, say the words and ask volunteers to point to their pictures on the pages.

Draw a drop of water or a glass of water. Elicit what it is and ask students what we use water for (*to wash our hands, drink, cook, etc.*). Briefly, make students aware of how important this resource is.

Unit 3

Let's Follow Instructions!

Curricular Objectives

- (A) Interpretation and follow-up of instructions.
- (B) Follow and give instructions for planting a plant.

Environment Academic and educational

Final Product Illustrated instructions for planting a plant.

Big Book A Different Way to Grow Plants

Achievements

Explore illustrated instructions. Understand and express instructions. Participate in the writing of texts of experiments.

Suggested Materials a plant, a glass of water, a piece of candy

Warm Up

Students need to recall their prior knowledge of plants and what they need to grow and survive. You could draw an incomplete plant on the board and have students identify it:

T: *Is this a plant?*

Ask them what it needs. Put the glass of water and the candy on the table. Ask a volunteer to give the plant what it needs. Students could then say what else a plant needs to grow: light, soil and air.

Unit 3 Overview

1 Look at the picture and answer the questions.

To begin, students could work in pairs to describe what they see in the picture (*a classroom*). You could read the materials in the list on the board in the picture for students to repeat and then find in the picture: soil, sand, seeds, water. They can also refer to the Picture Dictionary. You could point out the Final Product in the chart and elicit ideas from students about what they will achieve in this unit.

Before students discuss the questions, you could read them out loud and explain their meaning to the class. Students can then ask and answer the questions in pairs before sharing their ideas with the class.

Unit 3

Let's Follow Instructions!

Unit Overview

Environment: Academic and educational

Curricular Objectives:

- (A) Interpretation and follow-up of instructions.
- (B) Follow and give instructions for planting a plant.

Environment: Academic and educational

Final Product: Illustrated instructions for planting a plant.

Big Book: A Different Way to Grow Plants

1 Look at the picture and answer the questions.



1. Are children working individually, in pairs or in groups?
2. What are they doing?
3. Can you name any of the materials on the tables?
4. What are the materials for?
5. Would you like to do an experiment?

Circle your answers.

• Can you identify instructions for experiments?	Yes	Sometimes	No
• Can you understand and express instructions?	Yes	Sometimes	No
• Can you complete instructions?	Yes	Sometimes	No

20 Unit 3

How Will It Do?





This activity will help you check comprehension and get to know your students better. We suggest that you explain to students that they should read and answer about themselves. Three volunteers could take turns reading the questions and possible answers out loud.

Wrap Up

Play Draw It! on page xii with the class. Instead of parts of the body, students should draw materials used to grow a plant.

Answers: ► 1. They're working in groups. 2. They're planting seeds/doing an experiment with plants. 3. Jars, seeds, water, seeds, sand, soil. 4. To do an experiment with plants.

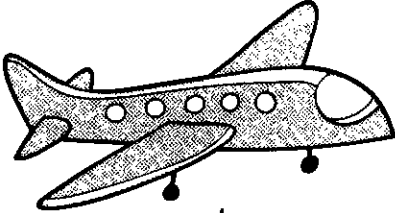
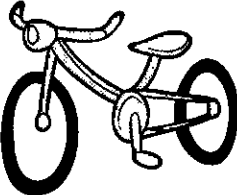
P. 18

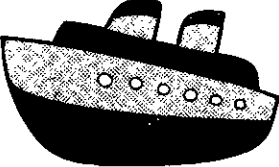
<p>1</p>  <p>red car</p>	<p>4</p>  <p>yellow truck</p>
<p>2</p>  <p>green plane</p>	<p>5</p>  <p>orange bike</p>
<p>3</p>  <p>blue train</p>	<p>6</p>  <p>brown ship</p>



P. 14

sea	dock	clock	one	four
shoe	two	Boo!	your	sun
blue	tree	door	pea	bee
down	we	three	Whee!	floor



Term 1

Picture Dictionary

Unit 2

Poem

Roses are red verse

Violets are blue

I love my Mom stanza

And she loves me, too.

Words for rhymes



bun

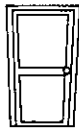

door



pea



glue



sun



you

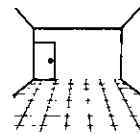

floor



tree

Term 1

Evaluation Instrument

Unit 2

Value Scale

1 The following descriptive rating scale can be used to assess students. Choose the descriptor that best fits student's performance.

Name: _____

Date: _____

Aspect To Be Observed	Pass criteria			In need of improvement	
	Exceptionally effective	Highly effective	Effective	Minimally effective	Not effective
Explore illustrated rhymes and tales in verse.	Can rapidly identify topic, purpose and audience and distinguish textual components	Can promptly identify topic, purpose and audience and distinguish textual components	Can identify topic, purpose and audience and distinguish textual components	Can identify topic, purpose and audience and distinguish textual components with frequent mistakes and noticeable hesitation	Has noticeable difficulties identifying topic, purpose and audience and distinguishing textual components
Listen to and participate in the reading of rhymes and tales in verse.	Can accurately discover the meaning of words, identify rhyming words, relate pictures to verse, practice pronunciation and identify stanzas and verses	Can almost always discover the meaning of words, identify rhyming words, relate pictures to verse, practice pronunciation and identify stanzas and verses	Can sometimes discover the meaning of words, identify rhyming words, relate pictures to verse, practice pronunciation and identify stanzas and verses	Can discover the meaning of words, identify rhyming words, relate pictures to verse, practice pronunciation and identify stanzas and verses by using only a few expressions with frequent mistakes and noticeable hesitation	Cannot discover the meaning of words, identify rhyming words, relate pictures to verse, practice pronunciation or identify stanzas and verses
Write verses.	Can complete and compare words with or without rhymes, complete verses, write verses based on a model	Can almost always complete and compare words with or without rhymes, complete verses, write verses based on a model	Can sometimes complete and compare words with or without rhymes, complete verses, write verses based on a model	Can complete and compare words with or without rhymes, complete verses, write verses based on a model despite difficulties and some hesitation	Cannot complete and compare words with or without rhymes, complete verses, write verses based on a model despite difficulties and some hesitation

Product Template

Words that rhyme

1 Complete with words that rhyme with the numbers.

Then illustrate the words you wrote.



one _____

two _____

three _____

four _____

2 Choose two pairs of rhyming words from pages 15 and 16.

Write them below and illustrate them.



word: _____ illustration

word: _____ illustration

word: _____ illustration

word: _____ illustration

3 Choose a rhyme from this unit. Write it and illustrate it.



Final Product

1 Present an illustrated rhyme.

1. Take out your illustrated rhyme from Activity 12 on page 18.
2. Work with a classmate and practice reading your rhyme out loud.
3. Present your rhyme to your classmates.
4. Remember that you can act out the rhyme using body movements.

Jack and Jill
 Jack and Jill went up the hill
 To fetch a pail of water
 Jack fell down and broke his crown
 And Jill came tumbling after











Group Reflection

- Was it easy to present your rhyme?
- Did you enjoy acting out the rhyme?
- Did you like your rhyme?

Self-evaluation

Color the faces according to what you can do.

- Can you read rhymes?  
- Can you say rhymes?  
- Can you recognize rhyming words?  
- Can you write rhymes and illustrate them?  

Achievements

Illustrate rhymes. Present rhymes. Reflection and self-evaluation.

Final Product

1 Present an illustrated rhyme.

Instructions

We suggest that you go over the steps for the presentation together with students. You could put students into groups and let them organize themselves on how they would like to present the rhyme and the type of presentation they would like to give. Collect the poems and put them in students' folders.

Group Reflection

We suggest that you read the questions aloud and have students discuss their answers in the same groups.

Self-evaluation

You could read the questions. Tell students to color the faces according to how well they feel they achieved the objectives.

Evaluation

Photocopy the Evaluation Instrument: Value Scale on page T19b (1 per student) and answer it for every student according to their performance.

Achievements

Complete verses with rhyming words. Write verses based on a model.

Suggested Materials Fiction Big Book

Warm Up

We suggest that you write rhyming words on the board, out of order and scattered around.

Invite students to come to the board and draw lines to match them.

11 Cut out and glue the pictures from Worksheet 2 on page 103. Then complete the rhyme. 2

Students should go to Worksheet 2 on page 103 and cut out the pictures of the vehicles. Then they should glue them in the correct numbered spaces and read the names.

We suggest you read "Looking Out of the Window" out loud. Then students should copy the names of the vehicles in on the correct lines.

► Work with a classmate. Take turns saying the verses of the rhyme.

Students should form pairs and take turns saying the verses of the rhyme, substituting the names of the different vehicles.

12 Final Product Preparation.

You could tell students to go to their Project Template on page 91 and do Activity 3. They should choose rhyme they have seen in this unit. Then they should write it and illustrate it on a sheet of paper. Tell them to keep it for the next class.

Wrap Up

 Time to read Fiction: Do the Elephant

Walk  32

Display page 3 of the Fiction Big Book. Ask students if they remember the title of the story.

Play Track 32 as you turn the pages. Play the track again and stop just before the rhyming words on each page. Encourage students to try to finish the verses.

Continue playing the story for students to check their guesses.



11 Cut out and glue the pictures from Worksheet 2 on page 103. Then complete the rhyme.

1	2
3	4
5	6

Looking Out of the Window

Looking out of the window, 3. a
What do you see? 4. o
I see a red car following me. 5. on
2. a 6. o

► Work with a classmate. Take turns saying the verses of the rhyme. 

12 Go to the Project Template on page 91 and complete activity 3. Write and illustrate the rhyme you chose on a clean sheet of paper and keep it for the next class.  

9 Listen and circle the words that rhyme. (10)

How Many Apples?

How many apples,
Do you see?
Can you count them?
One, two, three.



How many green ones?
How many red?
Now eat an apple,
And go to bed.



Write the rhyming words and illustrate them.

Listen again and act out the rhyme. (10)

You have learned different rhymes in this unit. Go to the Project Template on page 91 and complete activity 3.

How Am I Doing?

- Read and mark (✓) what you can do.
- Identify title, stanza and verse.
 - Recognize rhyming words
 - Read rhymes.
 - Understand rhymes.

--	--	--	--	--	--	--	--	--	--

Write the rhyming words and illustrate them.

We recommend reading the rhyme again, stressing the rhyming words. Then students should write the rhyming words and illustrate them.

Listen again and act out the rhyme. (10)

Play Track 10 again. Students should act out the rhyme as they listen.

10 Final Product Preparation.

You could remind students of the rhymes they have learned in this unit. Students should go to the Project Template on page 9 and complete Activity 3 by choosing a rhyme and illustrating it.

How Am I Doing?

We suggest that you read the options in the box out loud. Students should mark the things that they feel they can do.

Achievements

Practice the pronunciation of verses.

Suggested Materials Fiction Big Book

Warm Up

We suggest that you say a number and have students clap. For example, if you say three, they should clap three times.

You could tape the picture of a dog on the board and imitate the sound it makes: *woof, woof!* Invite three volunteers to tape the pictures of the other animals on the board.

The class should imitate the sound each one makes.

9 Listen and circle the words that rhyme. (10)

First of all, you could point to the pictures and ask students the number of green and red apples. Then read the title of the rhyme.

We suggest that you play Track 10 and have students follow along. Students should circle the words that rhyme.

Wrap Up

Time to read Fiction: Do the Elephant Walk (32)

Display page 3 of the Fiction Big Book. Ask a volunteer to read the title of the story. Ask students to identify the animal in the story. Play Track 32 as you point to the pictures on the pages. Imitate the movements mentioned (walk backwards, wiggle, jump, etc.). Play the track again and encourage students to imitate the movements as they are mentioned.

Write the rhyming words on the board and ask a volunteer: What do the words have in common?

A: *They sound alike.*

Then ask: *Are the words written the same?* A: *No.*

Remind students that rhyming words sound alike but are not written alike.

Finally, read the text on page 4 until the beginning of the second verse:

T: *An elephant walks like this and that. He's terribly tall and...*

Encourage students to complete the verse. Continue with the other verses.

Answers: ▶ see, three; red, bed

Achievements

Identify stanzas and verses. Practice the pronunciation of verses. Encourage students to appreciate and enjoy literary expressions in English.

Suggested Materials paper (one piece per student), colored pencils

Warm Up

We recommend drawing a monkey on the board and having students identify the animal:

T: *Is this a mouse? Is this a monkey?*

You could ask students to draw a monkey on a piece of paper.

Students should color their monkey any color they choose. They should stand up and find students that have a monkey the same color as their own. Students with the same color monkey then stand together.

7 Read and answer.

We suggest that you write a simple meaning of a rhyme, a verse and a stanza on the board and explain if necessary.

Rhyme: a composition in verse that rhymes.

Verse: a line of writing in a poem.

Stanza: a series of lines in a poem or rhyme that are arranged together.

You could call students' attention to the arrows pointing to a rhyme, stanza and verse.

Then students should answer the questions.

Read the rhyme out loud line by line and have students count the number of monkeys and point to the corresponding pictures.

► Compare your answers with a classmate.

Students should compare their answers in pairs.

► Listen, sing along and act out the rhyme.

We suggest you play Track 9 at this time. Students should sing along and act out the rhyme.

You could ask three volunteers to come to the front and represent the monkeys. Help the class say the rhyme while the "monkeys" jump and fall out of bed.

7 Read and answer.



Three little monkeys jumping on the bed,
One fell off and bumped his head,
Mommy called the doctor and the doctor said,
"No more monkeys jumping on the bed!"



Two little monkeys jumping on the bed,
One fell off and bumped his head,
Mommy called the doctor and the doctor said,
"No more monkeys jumping on the bed!"



One little monkey jumping on the bed,
He fell off and bumped his head,
Mommy called the doctor and the doctor said,
"No more monkeys jumping on the bed!"

1. How many stanzas are there in the rhyme?

2. How many verses are there in the rhyme?

► Compare your answers with a classmate.

► Listen, sing along and act out the rhyme.

► Go to the **Final Product Preparation** on page 91 and complete activity 2.

16 Unit 2

8 Final Product Preparation.

You could remind students that the Final Product is an illustrated rhyme. They should choose and write two pairs of rhyming words from pages 15 and 16, and write them in the spaces.

Answers: 7 3, 4

6 Listen to the rhyme and follow along. 8

These are Grandma's spectacles,
This is Grandma's hat.
This is the way she folds her hands,
And lays them in her lap.

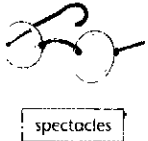

- ▶ Read the rhyme and underline the rhyming words.
- ▶ Read the rhyme again and match the words in blue to the pictures.
- ▶ Say the rhyme out loud. Use the pictures to help you act out the rhyme.

Unit 2 15

Achievements

Express emotions and reactions to actions, characters or places. Identify rhyming words.

Suggested Materials colored pencils

Warm Up

You could draw on the board one half of a hat. Invite a volunteer to draw the other half. Students should say what it is. Do the same with a pair of spectacles.

6 Listen to the rhyme and follow along. 8

We suggest that you play Track 8 and tell student to follow along. Then you could say read the words under the drawings.

- ▶ Read the rhyme and underline the rhyming words.

Students should underline the rhyming words in "Grandma's Spectacles."

- ▶ Read the rhyme again and match the words in blue to the pictures

You could refer students to the rhyme again and read it out loud. Students should draw lines to match the words in blue to the corresponding pictures.

- ▶ Say the rhyme out loud. Use the pictures to help you act out the rhyme.

Students should form pairs and practice saying the rhyme to each other and acting it out. They could look at the pictures to help them

Wrap Up

You could write the following rhyme on the board and say it first. Then students should repeat after you. We suggest clearing up any doubts about new vocabulary. Then a student could come to the front and circle the rhyming words: *pouring-snoring-morning, head-bed*

It's raining, it's pouring;
The old man is snoring.
He bumped his head
And went to bed
And couldn't get up in
the morning.

Answers: ▶ hat-lap

Achievements

Discover the meaning of words. Identify rhyming words.

Suggested Materials 10 balloons (1 red, 2 green, 3 purple, 4 orange), tape, colored pencils

Warm Up

We suggest that you stick on the board one red balloon, two green balloons, three purple balloons, and four orange balloons (or draw them on the board if you do not have any). Point to each group of balloons as you say the number. Have students say the number after you.

Then you could ask individual students to say a number and stand below the corresponding balloons.

2 Color the balloons according to the numbers.

We recommend reading of the You could write the numbers on the board and have students say them after you.

You could also point to the colorless balloons the mice are holding. Student should color the corresponding number of balloons.

3 Listen to your teacher say the words and follow along.

We suggest that you read the words out loud and ask students to follow along.

► Practice saying the words with a classmate.

Students should form pairs and practice saying the words with their partner.

► Color the words that rhyme. one two tree four

Say each number again. After you say a number, read the words in the colorless balloons. Make sure you read slowly. Tell students to raise their hand when they hear a word that sounds the same as that number. Ask them to color the balloons the corresponding color.

► Work with a classmate. Take turns pointing to one word and saying a rhyming word.

We recommend making this a fun activity. Pairs should take turns saying a word and answering with a rhyming word.

2 Color the balloons according to the numbers.

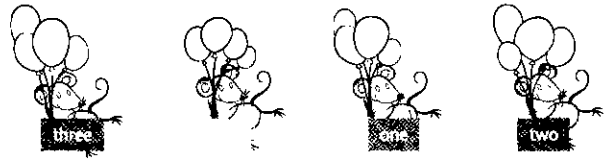

1 Listen to your teacher say the words and follow along.

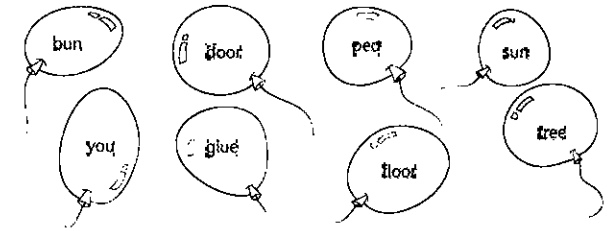

► Practice saying the words with a classmate.

► Color the words that rhyme. one two three four

► Work with a classmate. Take turns pointing to one word and saying a rhyming word.

4 In this unit your Final Product is an illustrated rhyme. Go to the Project Template on page 91. Choose some words from this lesson to complete Activity 1.

5 Go to Worksheet 2 on page 103 and play the game Snap!

14 Unit 2

4 Final Product Preparation.

In this unit the Final Product is an illustrated rhyme. We suggest you tell students to go to the Project Template on page 91. They should choose some words from this lesson to complete Activity 1.

5 Go to Worksheet 2 on page 103 and play the game Snap!

Students should cut out the cards from Worksheet 2 on page 103. They should form pairs, mix their cards together and distribute them evenly.

You could tell students to draw a card at the same time. If the words rhyme, the first one to place his/her hand on top and shout *Snap!* takes all the cards. The winner is the student with the most cards at the end.

Wrap Up

We suggest having student chant or sing the Number Song from Games and Activities on page xii.

Answers: ► one: bun, sun; two: you, glue, three: pea, tree

1 Listen to the rhyme and follow along. 

Hickory Dickory Dock

Hickory dickory dock

The mouse ran up the clock

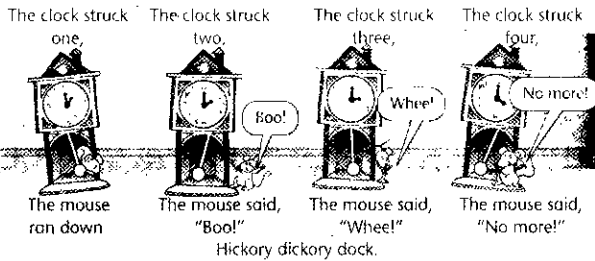

• Complete the information. 

1. Title of the rhyme:

2. The rhyme is about

and

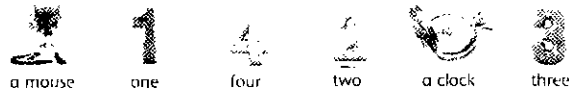

3. The rhyme is for



• Listen to the rhyme again and sing along. 

Unit 2 13

Achievements

Distinguish textual components. Identify the intended audience. Promote an atmosphere in which students can show confidence in the learning of English.

Suggested Materials Fiction Big Book

Warm Up

We recommend play Follow the Leader from the Games and Activities section on page xii.

Development

1 Listen to the rhyme and follow along. 

Draw a small circle on the board and ask students what it is. Continue drawing a mouse until students guess what it is.

We recommend play Track 7 now. Ask students to follow along on page 13 of their books while they listen to the track.

Then you could read the rhyme out loud and point to the illustrations that represent the main elements.

Ask questions about the meaning of the rhyme:

T: *Is this rhyme about an elephant? Is this rhyme about a mouse?*

This will help them identify topic, purpose and intended audience.

► Complete the information.

We suggest that you have student form pairs and complete the information about the rhyme.

You could ask who the rhyme is for and ask students to defend their answer. The ideal answer is *for children* but accept any answer.

► Listen to the rhyme again and sing along.

We suggest that you play Track 7 again and invite students to sing along.

Wrap Up

Time to read Fiction: Do the Elephant Walk

Display the Fiction Big Book and point to the picture on the cover on page 3. Have students identify the animal in the picture.

T: *Is this an elephant?* Ask students:

T: *Is this book about everyday situations?*

Is this book about stories?

Ask students about the kind of information they can find there. Have them identify the title and the author. Ask students what the story is about:

T: *Is this story about classroom objects?*

Flip through the pages for students to preview.

Go to page 4 and read each verse out loud. Have students repeat them after you. Invite different volunteers to say the verses to the class. Encourage them to walk like an elephant as they say the verses.

Repeat the rhyming words on each page and ask the students if they sound alike: *that-fat, toes-nose, this-is, right-side, about-shout*. Explain that this means that the words rhyme.

that-fat

Answers: ► Hickory Dickory Dock 2. a mouse, a clock 3. children, Answers may vary.

Unit 2

Let's Present a Rhyme!

Curricular Objectives

- (A) Literary expression.
- (B) Read rhymes and tales in verse.

Environment Literary and ludic

Final Product An illustrated rhyme

Big Book Do the Elephant Walk

Achievements

Anticipate topic, purpose and intended audience based on the title and previous knowledge.

Warm Up

We recommend writing on the board activities students do when getting ready to come to school: *wash my face, brush my teeth, comb my hair, eat breakfast, get dressed, tie my shoes.* You could invite individual students to come to the front, choose an activity and mime it. The others must guess what it is.

Unit 2: Let's Present a Rhyme!

1 Look and answer the questions.

We suggest that you read §“Hickory, Dickory, Dock” out loud. Explain that *hickory* and *dickory* are not real words and that *dock* is only important because of its sound. Read it again. Students should pay special attention to the sounds of the words. Then you could repeat the words *dock* and *clock* and ask students how these words sound: *similar, alike.* Say: *When words sound alike or very similar we say that they rhyme.*

Then you could have them answer the questions and share their answers. Ask them which word is needed to complete the rhyme.

How Much Do I Know?

Read the title of the unit out loud and explain that in this unit they are going to learn how to read and write a rhyme. You could ask if anyone knows what a rhyme is.

Unit 2
Let's Present a Rhyme!

Environment: Literary and ludic

Final Product: An illustrated rhyme

Big Book: Do the Elephant Walk

Achievements:
Anticipate topic, purpose and intended audience based on the title and previous knowledge.

Warm Up:
We recommend writing on the board activities students do when getting ready to come to school: *wash my face, brush my teeth, comb my hair, eat breakfast, get dressed, tie my shoes.* You could invite individual students to come to the front, choose an activity and mime it. The others must guess what it is.

How Much Do I Know?
Read the title of the unit out loud and explain that in this unit they are going to learn how to read and write a rhyme. You could ask if anyone knows what a rhyme is.

1 Look and answer the questions.

We suggest that you read §“Hickory, Dickory, Dock” out loud. Explain that *hickory* and *dickory* are not real words and that *dock* is only important because of its sound. Read it again. Students should pay special attention to the sounds of the words. Then you could repeat the words *dock* and *clock* and ask students how these words sound: *similar, alike.* Say: *When words sound alike or very similar we say that they rhyme.*

Then you could have them answer the questions and share their answers. Ask them which word is needed to complete the rhyme.

How Much Do I Know?

Read the title of the unit out loud and explain that in this unit they are going to learn how to read and write a rhyme. You could ask if anyone knows what a rhyme is.

1 Look and answer the questions.

1. What kind of text is it? How do you know? 2. Do you know any rhymes in your language? 3. Which word needs to go next?

How Much Do I Know?

Mark (✓) your answers.

• Can you identify rhymes?	Yes <input type="checkbox"/>	No <input type="checkbox"/>
• Do you read or listen to rhymes in your language?	Yes <input type="checkbox"/>	No <input type="checkbox"/>
• Can you write verses?	Yes <input type="checkbox"/>	No <input type="checkbox"/>

12 Unit 2

Poster

We recommend displaying Poster 2 at this time. You could do the Picture Dictation from the Poster Activities on page xi using one of the monkeys.

Wrap Up

Remind students that they should answer these questions about themselves. You could read the question out loud and clear up any doubts. Students should answer by marking the correct boxes

Finally, you could invite students to share rhymes in Spanish.

Answers: 1 1. It is a rhyme. 2. Because that last words rhyme. 3 Answers will vary. 4. down

Worksheet 1

▶ Look at the pictures and write.

Can you pass me the ruler, please?

Can I use your eraser, please?

May I come in, please?

Can I take a paintbrush, please?

Can you close the window, please?

Can you lend me your glue, please?

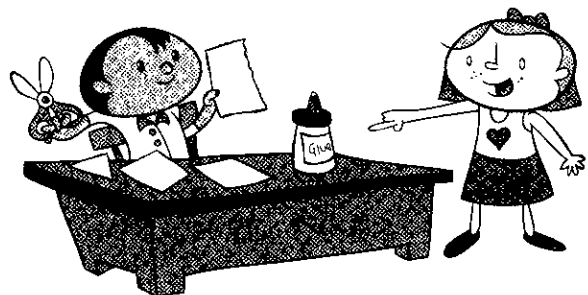
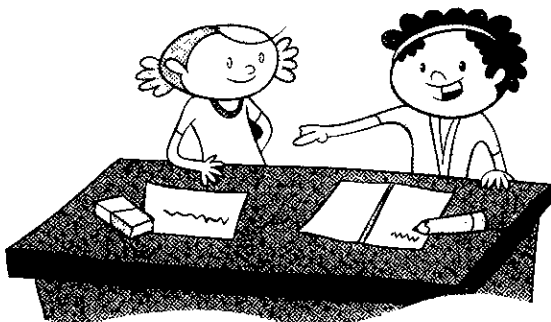
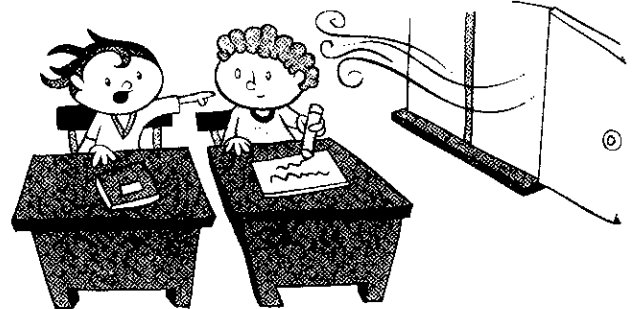
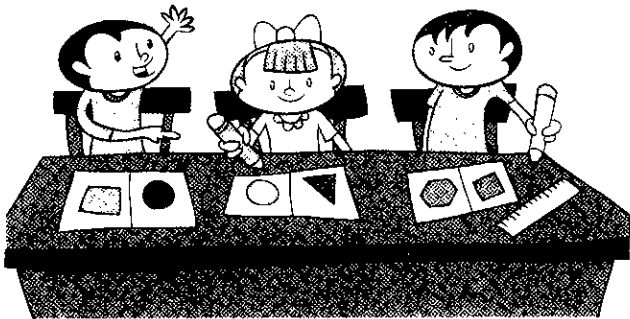
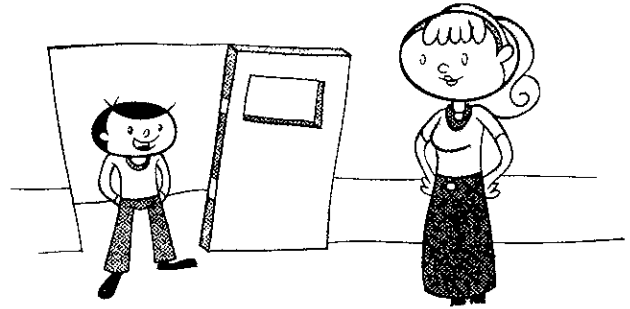
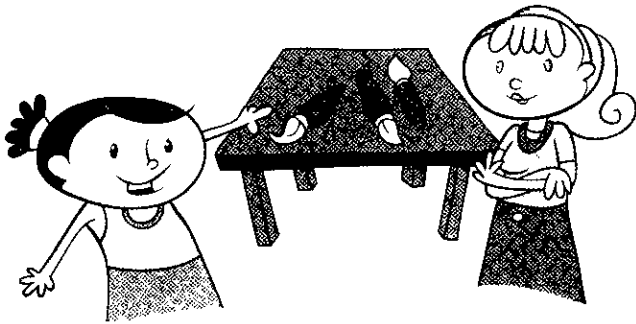

Picture Dictionary

Unit 1

Classroom Objects



book



colored pencil

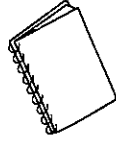

notebook



pen



pencil

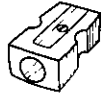

pencil sharpener

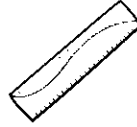

ruler



schoolbag



scissors



paintbrush



glue stick



eraser

The Classroom

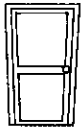

door

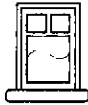

window

Evaluation Instrument

Unit 1

Observation Grid

1 The following observation guide can be used to assess students. Mark the rubric according to students' performance.

Name: _____

Date: _____

Aspects To Be Checked	Rubric				
	Able to do it easily and correctly	Able to do it correctly with minor difficulties	Generally able to do it correctly but with some difficulties	Sometimes able to do it correctly but with noticeable difficulties	Rarely able to do it correctly and with lots of difficulty
Detect participants and purpose in a dialogue.					
Distinguish turns of participation.					
Value attitudes of interlocutors and non-verbal language use.					
Point at words used in greetings, farewells and polite expressions.					
Compare similarities and differences between words and expressions.					
Choose, contrast and classify words and expressions according to rules of courtesy.					
Associate non-verbal languages with words and expressions.					
Take turns in a dialogue to express and respond to greetings, farewells and polite expressions.					
Dictate, rewrite and read norms of coexistence.					

Term 1

Product Template

Illustrated Role

Unit 1

Asking for a Favor	Greetings	Farewells
Asking for Things	Asking for Permission	Rules for

1 Make a list of classroom rules.

Suggested Materials

- white sheets of paper
- markers or colored pencils
- hole punch
- yarn or string
- scissors

Instructions

1. Join your team and take out your illustrated rules on page 10.
2. Put the sheets of paper together.
3. Use the hole punch and yarn or string to assemble the book together.
4. Read the rules out loud.
5. Place the book in a visible space.

Group Reflection

- Which part of the book did your team do?
- Which part did you do?
- Did you like the book of rules?

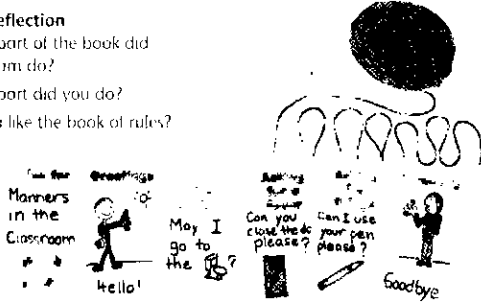

Self-evaluation

Reflect on the following aspects of your performance and mark (✓) your answers.

• I can identify rules for the classroom.	Yes	A little	No
• I can express myself politely in the classroom.	Yes	A little	No
• I know different expressions for greetings and farewells.	Yes	A little	No
• I can respect rules.	Yes	A little	No

Achievements

Associate illustrated norms of coexistence with words and expressions of politeness. Complete norms of coexistence. Read norms of coexistence. Point at illustrated coexistence norms. Reflection and self-evaluation.

Suggested Materials

construction paper, markers or colored pencils, hole punch, yarn or string, scissors

Final Product

1 Make a list of classroom rules.

You could go over each of the steps and make sure students understand what they have to do. We recommend guiding students but let them make their own decisions while doing the task.

Suggested Materials

Read the suggested materials together.

Instructions

We recommend reading the instructions out loud and checking to make sure students understand them. You could translate or explain any words they are not familiar with. When they have finished, students should share their rules out loud with the rest of the class or in groups.

Group Reflection

Tell students to work in the same teams as before to discuss their answers. At the end, they should express what they did and how they felt about it.

Self-evaluation

We suggest that you read the aspects out loud to make sure students understand them. Then they should mark (✓) their answers after each one. Read the questions. Tell students to color the faces according to how well they feel they achieved the objectives.

Evaluation

Photocopy the Evaluation Instrument: Observation Card on page T11b (1 per student) and complete it by following students' performance through the unit.

Achievements

Anticipate expressions used in greetings, farewells and to show politeness.

Suggested Materials Nonfiction Big Book box or paper bag, classroom objects from page T7

Warm Up

We suggest using the Color Search from the Games and Activities section on page xii. As an option you could tape polite expressions around the classroom for them to find.

15 Final Product Preparation.

We recommend that students continue with their teams and look again at the picture on page 6. They should discuss the rules the classroom rules the students in the picture need. This would be a good time to talk about the reason for and importance of classroom rules. Ask: *Is it easier to learn when their are classroom rules? Why is it important to be respectful of others?*

16 Listen to the audio and complete.

Tell students that there is a word missing in each of the sentences. Play Track 6. Students should listen and add the missing word to complete each sentence that.

► Final Project Preparation.

Students should add the new expression from Activity 15 to their Project Template.

17 Final Product Preparation.

We recommend reading through the steps for preparing the Final Project with the students. They should complete the *Rules for...* section and keep their work for the next lesson.

Answers: 14 Good morning. Can i borrow your eraser, please? May I come in, please? Can you pass me my pencil, please?

13 Look at the picture on page 4 and discuss the questions with your team.

1. Do the boys and girls in the picture need rules in the classroom?
2. What rules do they need in the classroom?

14 Listen to the audio and complete.

morning.

Can I borrow your eraser, please?

May I come in, please?

Can you pass me my pencil, please?

► Go to the *Project Template* on page 90 and complete it with expressions from activity 15.

17 Work together with your team from page 6. Go to the *Rules for...* section on page 90 and complete the section *Rules for...*

Now follow the steps below to start preparing your Final Product.

1. Each member of the team will choose two different rules from the *Rules for...* section.
2. Illustrate each rule on different sheets of paper.
3. Keep your work for the next lesson.

11 Listen to the audio and number the pictures.



12 Listen to the audio and fill in the blanks.

I, you

- 1. May I go to the bathroom, please?
- 2. Can you open the window, please?
- 3. Can you pass me my book, please?
- 4. May you come in, please?

• Write *P* (permission) or *F* (favor) for each question.

13 Go to Worksheet 1 on page 101 and do the activity.

14 Work with your team and go to the _____ on page 90, add some new phrases in sections *Asking for permission* and *Asking for a favor*.

Get in the same teams as in Activity 14. Go online and read the rules of the classroom. If possible, listen to the Rules for the Classroom song. Discuss with your team if you can use the same rules in your classroom.

Unit 1 9

Achievements

Classify with graphics, words, expressions and nonverbal language that meets norms of courtesy.

Choose, with the help of visuals, politeness expressions.

Suggested Materials Nonfiction Big Book

Warm Up

We recommend playing the Action TPR from the Games and Activities on page xii. You could use commands related to the expressions from the unit.

11 Listen to the audio and number the pictures.

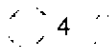

We suggest pointing to each of the pictures on page 9 and encourage students to tell you what is wrong or what is needed.

Play Track 4 and have them point to the corresponding picture. You could elicit the word that helped them find the picture. Play the recording again. Students should write the correct number in the box.

12 Listen to the audio and fill in the blanks.



We recommend writing the pronouns *I* and *you* on the board. Point to each of them and have students repeat after you while you point to yourself or to them.

Play Track 5 and have students fill in the blanks in the questions.

► Write *P* (permission) or *F* (favor) for each question.

Read the first question aloud and ask if it refers to permission or a favor. Students should write the answers on their own.

You could write *Permission* and *Favor* on the board and elicit the meanings of the words.

13 Go to Worksheet 1 on page 101 and do the activity.

This would be good time to do Worksheet 1. You could ask volunteers to read the questions out loud. Students should write the expressions under the correct pictures.

Collect the worksheets and put them in students' folders.

14 Final Product Preparation.

We recommend asking students to continue with their groups and complete the *Asking for a favor* section. They should also add any new phrases they have learned to the *Asking for permission* section.



For more on classroom rules, go to www.harrykindergartenmusic.com/song/204

Students should stay in the same teams as in Activity 14. They should go online and read the classroom rules. If possible, listen to the *Rules for the Classroom* song with your team and discuss if you can use the same rules in your classroom. This will help you prepare for the Final Product.

Wrap Up

Time to read Nonfiction: Being Polite

Go to page 3 of the Nonfiction Big Book.

Play Track 27 and have students follow along. Point to the pictures mentioned in the text. Go through pages 7 to 10 and ask students to identify expressions of courtesy:

T: *Point to a girl asking for permission.*

Answers: 11 3, 1, 2, 4 12 1. I, 2. you, 3. you, 4. I

► 1. P, 2. F, 3. F, 4. P 14 1 and 4

Unit 1

Achievements

Choose, with the help of visuals, politeness expressions, according to intended audience and communication situations. Take turns in a dialogue to express and respond to politeness expressions.

Suggested Materials Nonfiction Big Book, scissors, glue

Warm Up

Can I Borrow....? Mime. We suggest that you divide the class into large groups. We recommend preparing slips of paper with the names of a different classroom object on each one ahead of time. Give a slip of paper to one member of each group and ask them to mime asking to borrow the object for the others to guess.

8 Match the pictures to the questions.

Read the questions aloud while students follow along in their books. You could do the first one as an example. Then students should look at the pictures and draw a line from each set of pictures to the corresponding question.

9 Role-play: Ask for things politely.

You could read the names of the objects out loud and ask students to point to them as they are read. They can either point to the actual object or use their Picture Dictionary on page 84 to identify the objects.

Students should form pairs and take turns practicing the dialogue using the objects listed. Encourage them to exchange roles. Some pairs could perform in front of the class.

10 Final Product Preparation.

We recommend that students continue to work with the groups they formed when doing page 6. They should use the expressions they have learned on these last two pages to fill in the *Asking for things* and *Asking for permission* sections in the Project Template.

Answers: 8 Pencil sharper-Can I borrow a pencil sharpener, please? Ruler-Can I use a ruler, please? a toilet-May I go to the bathroom, please? Colored pencils-Can I have some colored pencils, please?

Match the pictures to the questions.



May I go to the bathroom, please?

Can I use a ruler, please?

Can I borrow a pencil sharpener, please?

Can I have some colored pencils, please?

Role-play: Ask for things politely.

pen
pencil
pencil sharpener
notebook
book
schoolbag
paintbrush

colored pencil
ruler
glue stick
scissors



13 In this lesson, you learned some polite expressions. Work with your classmates from page 6. Go to the *Asking for things* and *Asking for permission* sections on page 90 and complete the sections *Asking for things* and *Asking for permission*.

8 Unit 1

Wrap Up

Time to read Nonfiction: Being Polite

Display the Nonfiction Big Book and ask students to point to the title and to the picture. Ask students about the kind of information they can find there:

T: *Is this book about stories? Is this book about everyday situations?*

Go to page 3 and read the title out loud. Go to pages 4 and 5 and ask students to identify expressions of greeting:

T: *Point to a boy greeting another boy.*

Then hold up and read pages 6-8 and have students practice the dialogues on these pages using different objects. The first team to guess wins a point.

How Am I Doing?

Discuss these questions with a classmate.

- Do you know expressions to say hello and goodbye in different ways?
- Can you role-play a dialogue to say hello and goodbye?

7 Read and color.

asking for things =

asking for permission



• Role-play the dialogues with a classmate.

7 Look at the pictures below. Work with a classmate and ask for things or for permission using the expressions from Activity 6.

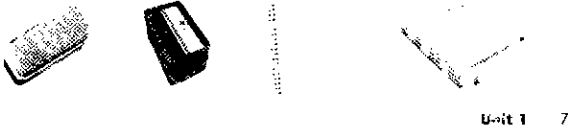

Unit 1 7

Achievements

Classify with graphics, words and expressions according to norms of courtesy.

Suggested Materials book, colored pencil, crayon, eraser, glue, glue stick, notebook, pen, pencil, pencil case, pencil sharpener, ruler, schoolbag, toy, scissors, paintbrush

Warm Up 3

You could do the action of arriving to the classroom and elicit some greetings (Hello, Hi, Good morning, etc.).

Then act as if you were leaving the classroom and elicit farewells (Bye, See you later, Goodbye, etc.).

It would be a good idea to make sure that you have the materials mentioned in the song: a book, a glue stick, a crayon and an eraser. Try to collect as many as possible before the class. The objects are shown in the Picture Dictionary on page T11c. Name each one and students should repeat after you.

You could hold up the objects mentioned as you play Track 3.

After the recording has finished, say the rhyme and substitute with the other objects listed in the Suggested Materials. Hold up the respective object as you name it. Repeat and ask students to hold up the classroom objects as they are mentioned.

How Am I Doing?

We suggest asking students to form pairs. They should read and answer the questions together.

6 Read and color.

We suggest that you write *asking for things* and *asking for permission* on the board and ask for an example of asking for permission. Then you could point to different objects and have students ask to use or borrow them.

T: *Can I use your pen, please?*

The students should read the questions. Ask them to use the corresponding color to fill in the circles. They can use their Picture Dictionary on page T11c.

► Role-play the dialogues with a classmate.

Students should choose partners and practice miming the dialogues. Then they could choose a dialogue and mime it for another pair.

7 Look at the pictures below. Work with a classmate and ask for things or for permission using the expressions from Activity 6.

Students should choose a partner. The partners should look at the items pictured and take turns using expressions from Activity 6.

Wrap Up

We recommend playing the game Pass It On from the Games and Activities on page xii.

As an added feature, you could ask the student left with the object when the music stops to say a question asking for the object: *Can I use the pencil?*

Answers: 6 1. red, 2 green, 3. red, 4 red

Achievements

Identify contextual features. Value attitude of interlocutors and nonverbal language use. Compare similarities and differences between words and expressions.

Suggested Materials scissors, glue

Warm Up

Have students stand up and say *Hello*. Have them sit down and say *Goodbye*. Ask each student to stand up and sit down as he or she says *Hello* or *Goodbye*.

3 Label the pictures with the correct expressions from the box.

You could start off by drawing students' attention to the pictures in the box. Ask them what time of day it is in each one and how they know: *the activities of the people, the view from the windows and the clocks on the walls*. Then you could ask four students to read the expressions in the box out loud. Students should write the correct expression under each picture.

► Listen to the audio and check.

Play Track 2 and have students check their answers. Students could point to the expressions as they hear them.

4 Look at the pictures. Take turns pointing to them and saying the correct expressions from Activity 3.

Students should look at the three pictures and say what the people in each picture are doing. We suggest dividing the class into pairs. Then students should take turn pointing to a picture and saying the expression that goes with it.

5 Final Product Preparation.

We suggest that you supervise while the students choose their teammates to make sure no one is left out. It may be necessary to have three or four on a team. We recommend having the students work with their teammates to complete the Greetings and Farewells sections of the Project Template. It is a good idea to set a time limit. Then you could ask the teams to share their answers and write them on the board.

3 Label the pictures with the correct expressions from the box.

Good morning. Good evening. Good night. Good afternoon.

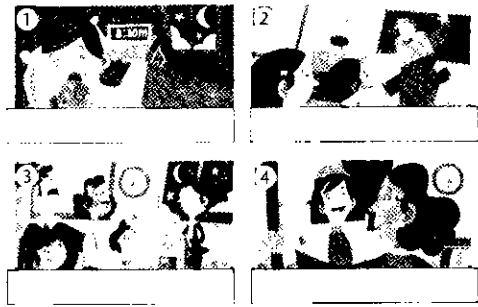

► Listen to the audio and check.

4 Look at the pictures. Take turns pointing at them and saying the correct expressions from Activity 3.



5 In this unit you will make a book of rules. Choose two classmates to form a team and make a book about rules as your class goes to the ... on page 90, complete the sections Greeting and Farewells with expressions you know to say Hello and Goodbye.

6 Unit 1

Wrap Up

Play a game of Charades using the Greeting and Farewell expressions. You could divide the class into two teams and give them expressions to mime. A member of each team mimes the phrase and their team has to guess the answer.

Answers: 3. 1. Good night 2. Good morning 3. Good evening 4. Good afternoon 4. Picture 1-Good morning. Picture 2-Good evening. Picture 3-Good afternoon. 5 Hello. Good morning. Good evening. Hi! Good afternoon. Goodbye: Bye! See you later. Good night.

Development

1 Look at the pictures and circle the correct words.

Hello / Goodbye Hello / Goodbye Hello / Goodbye Hello / Goodbye



▶ Listen and number the pictures.

- | | |
|------------------------------------|------------------|
| 1 Hello, Hello!
My name's John. | 3 Goodbye, Rose. |
| 2 Hello, Hello!
My name's Rose. | 4 Goodbye, John. |

Have a wonderful day!

2 Role-play the situations with different classmates.



Unit 1 5

Achievements

Detect participants and purpose of dialogue. Provide models of exchanges of greetings, farewells and politeness expressions. Associate nonverbal language with words and expressions.

Suggested Materials a soft ball, scissors, glue

Warm Up

Throw the ball to a student and say:

T: *My name is (Mariana).*

Ask him/her to throw the ball to a classmate and say his/her name. Ask students to continue throwing the ball until the whole class has said their names.

Development

1 Look at the pictures and circle the correct words.

To introduce the activity we suggest that you leave the classroom while waving and saying *Goodbye*. Have students reply.

Open the door and while saying *Hello*. Come into the classroom and greet students using their names. Then ask students to mark the corresponding word for each picture.

They should compare their answers in pairs.

▶ Listen and number the pictures.

Play the first two lines of the song. Students should point to the corresponding picture and write 1 in the box. Do the same with the following lines and pictures.

It would be a good idea to play Track 1 again while students follow along in their book. Encourage them to sing.

2 Role-play the situations with different classmates.

Students should form pairs. You could ask a more proficient student to read aloud the first speech bubble and have the class choose the corresponding picture. Then have them continue the activity on their own.

Ask students to stand up. Say one of the captions and ask them to role-play around the classroom, changing the names of the people.

You could ask students if they use expressions of greeting and farewell with their friends and family.

Wrap Up

Say a Greeting and invite three students to come to the board and draw a picture to represent the phrase. We recommend repeating the process until all students have had a chance to participate.

Answers: 1 Hello, Goodbye, Goodbye, Hello

▶ 1, 4, 3, 2

TERM 1

Unit 1

Let's Make List of Rules!

Curricular Objectives

- (A) Exchanges associated with specific purposes.
- (B) Use expressions of greeting, politeness and farewell in a dialogue.

Environment Family and community

Final Product Illustrated list of classroom rules

Big Book Being Polite

Achievements

Invite students to respect norms of coexistence. Classify with graphics, nonverbal language that meets norms of courtesy and one that doesn't.

Warm Up

Introduce yourself to the class:

T: *Hello! My name's (Celia).*

Ask a student:

T: *What's your name?*

Encourage him/her to respond:

S: *My name's (Carlos).*

Repeat with all your students.

Poster

Display Poster 1 and choose the Search and Spot activity from the Poster Activities on page xi. They could do the activity first with colors and then with the expressions. You could use the following descriptions for teams to find and color:

Unit 1 - Javier

1 Look at the picture and circle the situations that are wrong.

Students should look at the drawing and elicit where the people are, who they are and what they are doing. Then you could have students work in groups to find and circle the situations that are wrong in the picture.

► Discuss with a classmate.

We suggest reading the questions out loud and explaining their meaning to the class. Students count the number of situations and discuss which situations are wrong in pairs. Then they discuss which situations show correct actions and why they think they are correct.

Let's Make a List of Rules!

Unit 1 - Javier

Environment: Family and community

Learning Objectives	Activities	Assessment
1. Exchange greetings and farewells in a dialogue.	1. Exchange greetings and farewells in a dialogue.	• Exchange greetings and farewells in a dialogue.
2. Use expressions of greeting, politeness and farewell in a dialogue.	2. Use expressions of greeting, politeness and farewell in a dialogue.	• Use expressions of greeting, politeness and farewell in a dialogue.

1 Look at the picture and circle the situations that are wrong.



- Discuss with a classmate.
- 1. How many wrong situations are there?
- 2. Which situations show correct actions?

Unit 1 - Javier

Circle the answers.

- | | | | |
|---|------|------------|-----|
| 1. Is it easy to identify wrong situations? | Yes. | Partially. | No. |
| 2. Is it easy for you to respect rules? | Yes. | Partially. | No. |
| 3. Can you use polite expressions in conversations? | Yes. | Partially. | No. |

Unit 1

Unit 1 - Javier

This activity will help you check comprehension and get to know your students better. We suggest that you explain to students that they should read and answer about themselves. Three volunteers could take turns reading the questions and possible answers out loud. Clear up any doubts about new vocabulary.

Wrap Up

Go to the Games and Activities on page xii. You could do the Greetings activity, using a toy to say *hello*. Then pass it to each student, one at a time, so they can greet a classmate in the same way.

Answers: ► 1. A boy is arriving late, a girl is standing at the front of the classroom, a boy is running out of the classroom, two children are arguing. Although the class has started, no one is paying attention to the teacher. 2. A girl is giving an eraser to a boy, A boy is paying attention to the teacher.

Unit 9 Let's Make a Chart!

Environment: Academic and educational

Social Practice: Interpret information about units of time, with support of a graph.

Communicative Activities: Exchanges associated with specific purpose

Final Product: Information on the American continent for a chart.

Big Book: The Americas

Achievements

- Explore illustrated maps of the American continent with specific information (language, currency, flag, etc.).
- Understand information from reading aloud.
- Participate in writing information.

Unit 10 Let's Make a Map!

Environment: Family and community

Social Practice: Understand and register information about locations in the community.

Communicative Activities: Exchanges associated with the environment

Final Product: Map with information about community localities.

Big Book: Children of the World

Achievements

- Explore illustrated diagrams or maps.
- Exchange information about localities of the community.
- Write information about the community.

Unit 7 Let's Make a Bar Graph!

Environment: Family and community

Social Practice: Exchange information on personal data.

Communicative Activities: Exchanges associated with information of oneself and of others

Final Product: Information about hobbies for an illustrated graphic.

Big Book: Collections

Achievements

- Revise the writing of personal data and hobbies.
- Understand questions about personal data and hobbies.
- Participate in the writing of questions about personal data and hobbies.

Unit 8 Let's Make a Hanging Mural!

Environment: Family and community

Social Practice: Read stories to compare emotions.

Communicative Activities: Understanding oneself and others

Final Product: Illustrated sentences related to own experiences, for a hanging mural.

Big Book: The Frog Prince

Achievements

- Explore an illustrated book of children's tales.
- Listen and follow the reading of a tale.
- Compares emotions caused by the reading of a tale.
- Participate in the writing of sentences.

Unit 5 Let's Read Poems!

Environment: Literary and ludic

Social Practice: Change verses in a children's poem.

Communicative Activities: Recreational expression

Final Product: Illustrated verses of a poem.

Big Book: The Noisy, Busy Farm

Achievements

- Explore illustrated children's poems.
- Participate in reading aloud children's poems.
- Complete written poems.

Unit 6 Let's Make a Questionnaire!

Environment: Academic and educational

Social Practice: Write questions for information on agricultural products.

Communicative Activities: Search and selection of information

Final Product: Questionnaire to get information on fruits and vegetables.

Big Book: All About Fruits and Vegetables

Achievements

- Explore illustrated children's books about agricultural products.
- Participate in the exchange of questions and answers on agricultural products.
- Review writing questions to get information.

Unit 3 Let's Follow Instructions!

Environment: Academic and educational

Social Practice: Follow and give instructions for planting a plant.

Communicative Activities: Interpretation and follow-up of instructions

Final Product: Illustrated instructions for planting a plant.

Big Book: A Different Way to Grow Plants

Achievements

- Explore illustrated instructions.
- Understand and express instructions.
- Participate in the writing of texts of experiments.

Unit 4 Let's Make Signs!

Environment: Family and community

Social Practice: Produce signs for public spaces.

Communicative Activities: Exchanges associated with media

Final Product: Own signs..

Big Book: Taking a Walk

Achievements

- Analyze signs.
- Rehearse the oral expression of instructions in signs.
- Participate in the writing of instructions.

Scope and Sequence

Unit 1 Let's Make a List of Rules!

Environment: Family and community

Social Practice: Use expressions of greeting, politeness and farewell in a dialogue.

Communicative Activities: Exchanges associated with specific purposes

Final Product: Illustrated list of classroom rules.

Big Book: Being Polite

Achievements

- Revise exchanges of greetings, farewells and politeness expressions in short dialogues.
- Assume the role of a receiver and a sender to exchange greetings, farewells and politeness expressions.
- Participate in the writing of classroom norms for coexistence.

Unit 2 Let's Present a Rhyme!

Environment: Literary and ludic

Social Practice: Read rhymes and tales in verse.

Communicative Activities: Literary expression

Final Product: Illustrated rhymes in verse.

Big Book: Do the Elephant Walk

Achievements

- Explore illustrated rhymes and tales in verse.
- Listen to and participate in the reading of rhymes and tales in verse.
- Participate in the writing of verses.

Routine Games and Activities

The following is a list of routine activities that you can do with your students. The repetition of these routines will allow students to gradually acquire useful high-frequency vocabulary.

✧ Greetings

Use a large doll or toy to greet individual students:

Doll: *Hello, (Karla).*

S: *Hello.*

Pass the doll around to various students and give them an opportunity to use it to greet their friends.

✧ Action TPR

Give students commands. As you give each command, do the action yourself so that students can understand what they should do:

T: *Stand up! Raise your hand! Turn around! Jump!*

✧ Follow the Leader

Have students stand up and make a circle.

Clap your hands and invite students to do the same. Continue the procedure with other actions: *dance, shake your head, march, stomp your feet.*

✧ Color TPR

Stick paper circles of different colors on the classroom walls and have students name the colors.

Give instructions for students to identify and go to appropriate circles:

T: *Walk to blue.*

Repeat with different colors and other verbs (*jump, hop, march*). Demonstrate the actions if necessary.

✧ Color Search

Divide the class into small teams. Assign a color to each team. Students walk around the room looking for real objects of the same color.

Students bring the objects back to their table, hold each up and name it.

✧ Number Song

Teach students the following song, sung to the tune of "Ten Little Indians":

Ten Little Children

One little, two little, three little children,
Four little, five little, six little children,
Seven little, eight little, nine little children,
Ten little children, yeah!

✧ Pass It On

Students stand in a circle. Distribute about 10 different school supplies. Play some music. As the music plays, students pass the objects around the circle. Stop the music. Ask the students with the objects to name them.

✧ Draw It!

Divide the class into four teams and divide the board into four columns. Ask a member of each team to go to the board and stand in front of their column. Give them a piece of chalk. Say:

T: *This is my (mouth).*

The students draw that part of the body. The first to finish, wins a point for his/her team.

✧ Animal Charades

Divide the class into two teams. Have a student from Team 1 mime an animal. The other team members guess the animal in less than a minute to get a point. Follow the same procedure for Team 2.

✧ Fruit Bowl Upset

Assign a fruit to each student: *apple, banana, orange, watermelon, pear*. Give each student a small piece of paper. Have them draw a picture of their fruit.

Then have students play a game. When you say the name of their fruit, students should stand up and change places. When you say *Fruit bowl upset*, they must all change places.

✧ Peter Is In the Kitchen

Draw a simple house on the board: *a kitchen, a bathroom, a living room and a bedroom*. Draw a picture of a boy and cut it out to make a puppet.

Hold up the puppet and have him move to different rooms:

T: *Peter is in the kitchen.*

Then teach students the following rhyme:

Kitchen, bathroom, living room, bedroom.

These are the rooms. I live in here.

Kitchen, bathroom, living room, bedroom.

Where will the (boy) appear?

Have students close their eyes as you put the puppet in different rooms. Lead students in chanting the rhyme and answering the question.

Poster Activities

Make the best use of posters in your class.

Presentation

Ask the class to look at the poster and notice what is going on. Model language and have volunteers point to specific words on the poster. Practice pronunciation and check concepts by switching the order of words or pointing to incorrect words so that your students correct you. Have some students be teachers and ask their classmates.

Picture Dictation

Before showing the poster to your students, ask them to take out a piece of paper and draw what you describe (a part of the poster or a character). It is important that students identify vocabulary such as *in the middle of, at the top / at the bottom, left / right, etc.*

When you are describing the picture, it is best to describe one object at a time slowly and to repeat each description two or three times. Make sure you give students enough time to finish drawing one object before you move on to the next object. It is a good idea to walk around and look at what students are drawing so that you can see how well they understand your descriptions. Then you can adjust your descriptions appropriately and give students any support they need.

When you show the poster, have students compare what they drew and see if it is similar.

Search and Spot

Divide the class into teams of four and give each team magnets or stickers to cover the items they find on the poster as you mention them. You can have a race to see which team finds the items first.

Find Items Beginning/Ending with...

To practice letters or sounds, instruct your students to tell you about items beginning / ending with a specific sound or letter they can see on the poster.

How Many Can You Find

To practice numbers, ask your students to count specific items on the poster.

Choose an Item

Have a student choose an item from the poster and keep it secret. Others can guess what he/she has chosen by asking questions that can only be answered with *yes* or *no*. Limit time and number of questions.

Place In Alphabetical Order

Direct students to order alphabetically a category of words: *animals, signs, buildings, colors, etc.*

Make Up a Story

Place five counters on the poster. Have students make up a short story which includes the items covered by the counters.

Copy the Poster

Ask students to draw in the notebook a copy of the full poster and write the meaning of some items next to them.

Create a Poster

Divide the class into five teams. Display the poster and ask students to create another version of the poster on a large piece of cardboard.

Running Dictation

Divide the class into teams of three. Every team has a designated drawer / writer. The drawer / writer should not be facing the poster. The other two members are runners.

Write two to six questions or drawing tasks on a paper and show it to the runners. The runners should take turns looking at the poster closely to find the information to answer the questions. Once they think they can remember the information, they go back to their drawer / writer and dictate the information or describe the picture to him/her. He/She writes the answers or draws what is needed.

What Is Missing?

Show students the poster for 30 seconds. Ask them to close their eyes and try to memorize the images on the poster. Have them open their eyes and write down or draw as many things as they can remember.

Optional: Allow them to look at the poster for 10 seconds once again and add to their lists or drawings. Finally, show the poster again so they can compare it with what they wrote or drew.

Digital Component

× Audio Program

Yes, *We Can!* includes an extensive listening program. The wide variety of activities recorded on the CD will help all students, and in particular auditory learners, to assimilate the language. All of the chants, songs, rhymes, pronunciation and other listening exercises for the program are included on this CD, as well as all the Big Book stories. You will find this icon together with a number so that you know which track you should play for each activity:

Recorded by native speakers, these recordings provide excellent pronunciation models. A transcript of the entire Audio CD is included in the Teacher's Guide.

The following procedure is suggested for song/chant presentations:

- You may write the lyrics on the board or on chart paper.
- You could play the song or chant.
- You might want to present any new words through pictures, gestures or actions.
- You may want to play the song or chant a second time, assigning a listening activity to students. For example, you can have them make and hold up word cards for specific vocabulary or structures or have them perform a gesture or movement each time they hear a particular element.
- You can also have students read the lyrics with you as a student points to them on the board or chart.
- You could read the lines yourself and have students repeat after you, one line at a time.
- You may want to assign different lines or verses of the song to groups of students or individuals for additional practice.

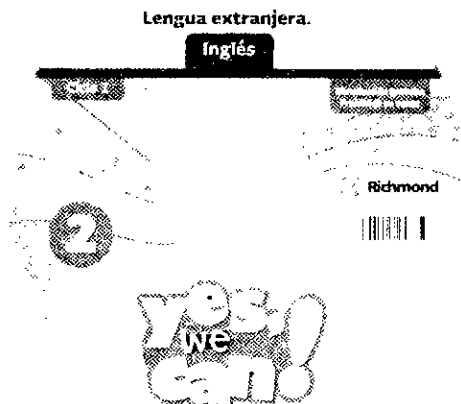

× Posters

The CD also includes a series of projectable posters, one per unit. You can use these to present or review vocabulary or to play different games. Suggestions on how and when to use these posters are given in this guide, and the activities to exploit them are on page xi.

Big Books

Authentic literature is an excellent source of real language and general knowledge. As cognitive, social and literacy skills are developed, students gain an appreciation of reading and books. Big Books are especially appealing to young learners because of their size.

The series includes a Fiction and a Nonfiction Big Book for each level. Each book contains stories related to the unit themes. You will find suggestions for their use integrated into the lessons.

Since young children generally love to listen to the same story many times, you can read the Big Books aloud or play the audio when ever you like.

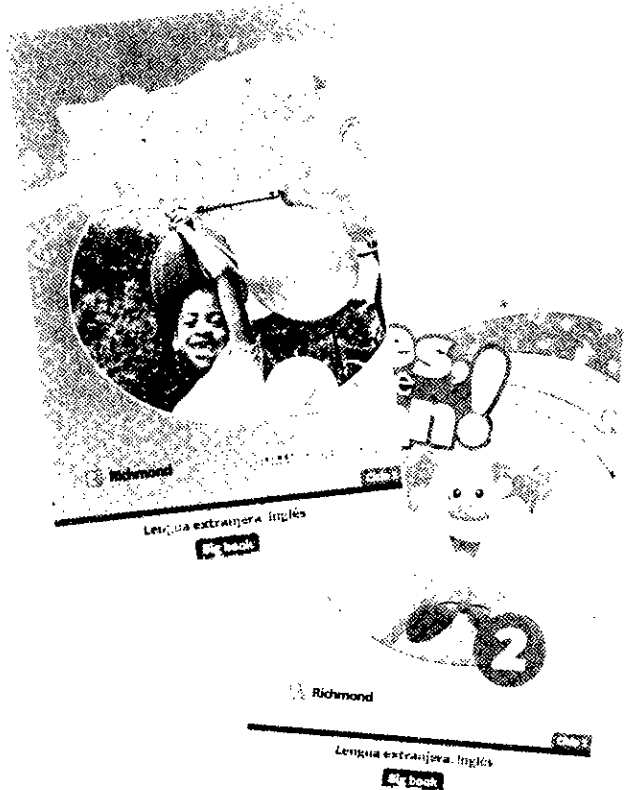

Teacher's Guide

The *Yes, We Can! Teacher's Guide* is a great tool for teachers. It will accompany teachers before and while giving classes. It gives easy-to-follow suggestions for fun and effective ideas on how to carry out the program. The corresponding reduced reproduction of the Activity Book pages are included for reference. You will also find the reduced version of the Product Template, Worksheets and Picture Dictionary.

✦ Scope and Sequence

On pages xiii to xvii of the Introduction section, you can find a scope and sequence that includes an at-a-glance summary of the contents of each unit, including the environment, the social practice, the communicative activity, the achievements, as well as the final product and Big Book text.

The *Yes, We Can!* Teacher's Guide includes suggestions for each lesson in the Activity Book. In addition to the reduced version of the Activity Book page, each lesson includes the following:

- a box with curricular objectives and suggested materials
- a suggested warm-up activity to do before each lesson in order to activate prior knowledge and introduce students to the new topic
- ideas for exploiting the stories and nonfiction texts from the Big Books
- suggestions for the development of portfolio materials
- suggested wrap-up activities to end the lesson

Evaluation in *Yes, We Can!*

Yes, We Can! includes several tools to measure students' performance. These help the teacher cover different types of evaluation: *summative*, *formative*, as well as students' *self-evaluation*. These tools are organized as follows:

✦ Evaluation Instruments

As part of the formative evaluation of the program, you will find a photocopiable Evaluation Instrument after each unit. These can be used to mark students' performance and progress throughout the unit, regarding the curricular objectives and achievements of the program. There is a wide variety of instruments, such as observation cards, evaluation rubrics, value scales, self-evaluation cards, questionnaires, among others. These help teachers complement the summative evaluation carried out with the use of the assessments.

✦ Assessments

As part of the summative evaluation, we have included one photocopiable assessment every two units.

Apart from those assessments, there is a summative assessment per term:

Term 1 Assessment—Units 1 to 4

Term 2 Assessment—Units 5 to 7

Term 3 Assessment—Units 8 to 10

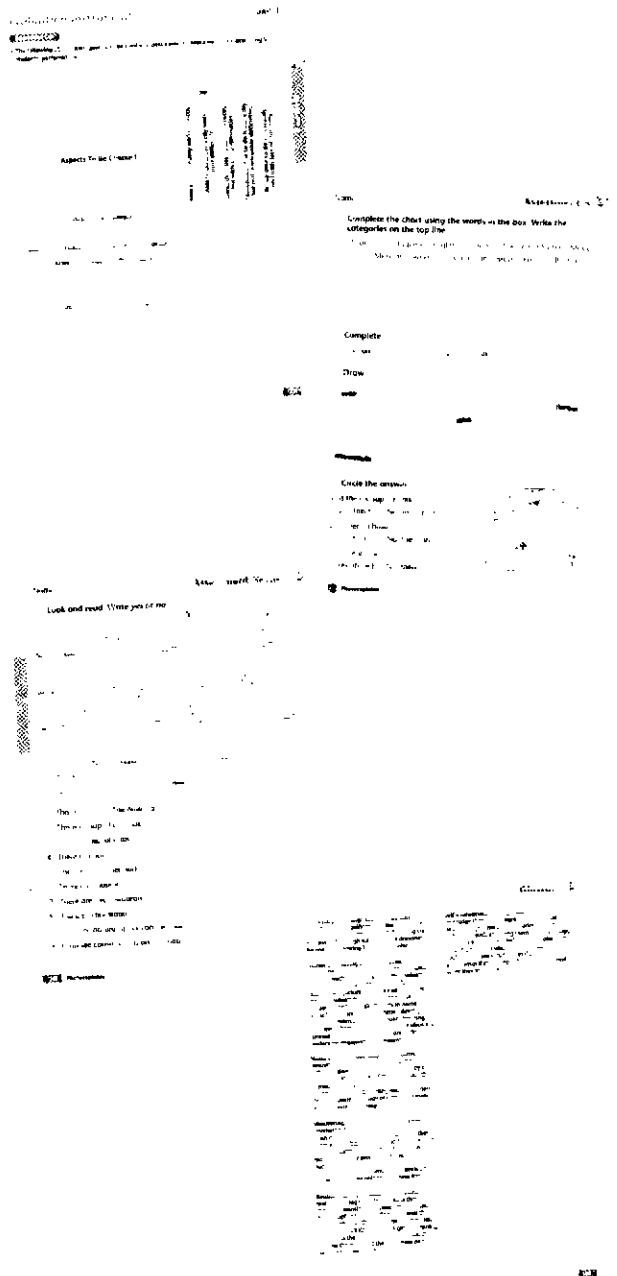

Components

Activity Book

The Activity Book is the main component for students. It includes attractive and fun activities that help students explore and practice the language as they go along. Every unit in the Activity Book is designed for one month of classes.

Students will find the Activity Book very friendly as its structure and icons clearly mark what should be done at each point. The instructions are easy to follow and the progression from setting objectives to creating the final product is very smooth.

Websites

There is reference to a website per unit by means of a URL. These provide students with further practice, games, songs or interactive activities they can do at home, with the help and supervision of their parents or guardians. If your school has access to computers, you can visit the websites during the English class. You will identify these with the following icon: 

Picture Dictionary

This Picture Dictionary will help students any time they have a doubt about the meaning of a high-frequency word. These words are highlighted and when words are not written but represented with a picture, students will know they can find them in the Picture Dictionary. The following icon will help them identify when they should refer to this section. 

Product Templates

Throughout the unit, students are asked to collect useful information on these templates. There is one template per unit. This page works as a sub-product and the information they include here will help them in the creation of their Final Product.

You will identify when to refer to this section by means of the following icon: 

Worksheets

In the Worksheets section, students will find materials that will help them in the development, preparation or practice for the Final Product. These will be marked with the following icon:

Bibliography

Students can use the list of books and websites listed here to find further practice. It is also useful for parents or guardians who are interested in providing help at home.

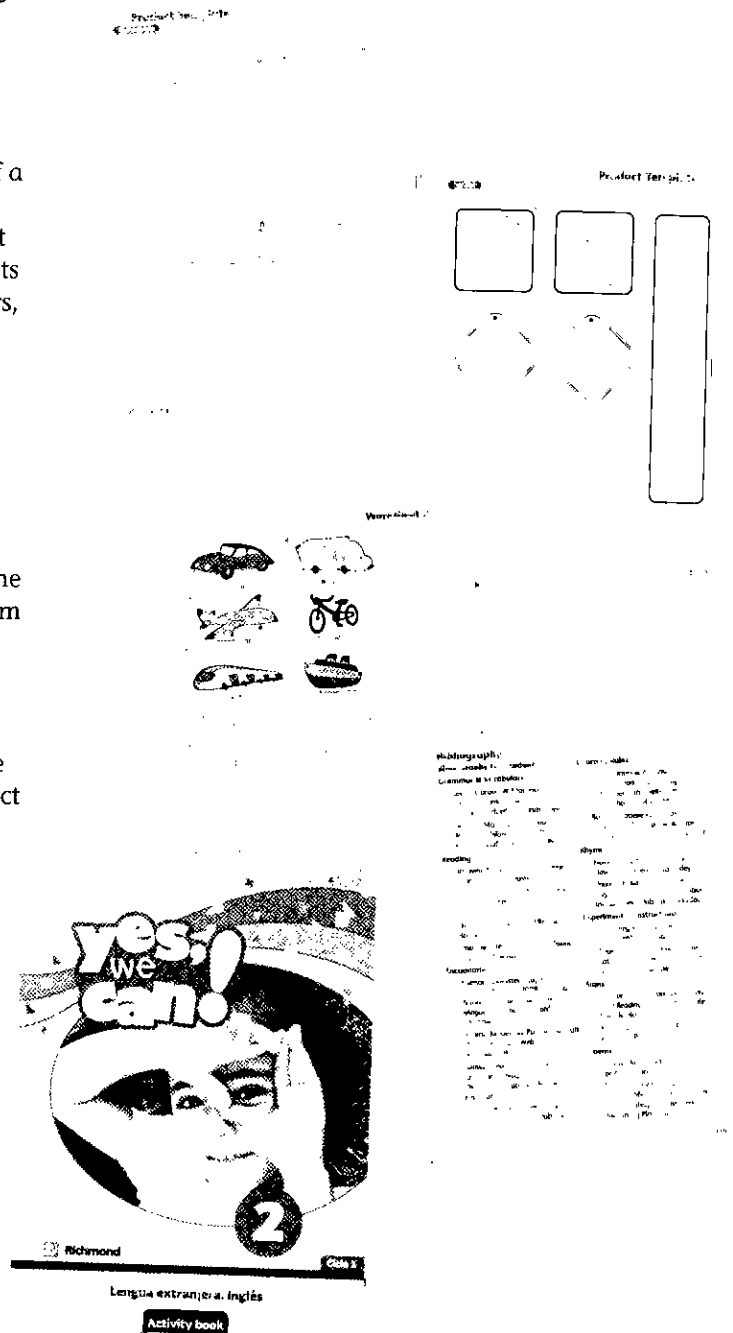

Icons of the Series

The following visual guide will help you become familiar with the icons you will find in the Activity Book. There is a brief description of what they represent. Further explanation on their role in the series is described in the *Course Structure* and *Components* sections within this introduction.

 **Audio**
This refers to the tracks you should play to carry out listening activities. The corresponding number is next to the icon.

 **Picture Dictionary**
When the high-frequency words of the unit are illustrated for better reference, you will see this icon so students see the corresponding section at the back of the Activity Book.

Worksheet
This refers to the Worksheet of the unit. It's also numbered for better reference in each unit.

 **Product Template**
This represents the section of Product Templates that students should go to in preparation for their Final Product.

 **Portfolio**
When you see this portfolio icon, it means that students can keep their work as evidence of their progress and include it in their portfolio.

 **Websites**
This refers to a link students can go to for further practice.

 **Big Books**
This icon will help you identify when you can use the Big Book in class.

Interaction Patterns

 This means the activity in the Activity Book should be carried out individually.

 This refers to activities that students should do in pairs.

 This shows when students work in groups or as a class. More detailed instructions are stated in the teacher's notes.

Course Structure

Yes, We Can! works around three environments: Family and Community, Literary and Ludic and Academic and Educational. Each environment helps students develop a variety of skills and abilities. The Family and Community environment opens up a space for students to use communicative language; The Literary and Ludic environment gives students opportunities to read and understand interesting and fun stories and play with the newly acquired language; the Academic and Educational environment teaches students how to look for and apply new information and how to follow and interpret instructions.

In *Yes, We Can!*, we alternate the environments throughout the units so that students are able to have different experiences every month.

Each unit of the program is organized in the following way:

Unit Overview

In this first section, the unit is referenced to the National English Program, by means of a chart, in terms of the corresponding learning environment, social practice, communicative activities, achievements and final product, as well as the corresponding story from the Big Book. There is also a short activity that is intended to activate the students' prior knowledge as well as to help them anticipate the contents of the unit.

How Much Do I Know?

The purpose of this diagnostic section is to help learners reflect on how much they know regarding the social practice and also to relate to the learning environments in a reflective way or by means of a short task.

Development

This section aims at covering the stages through which the social practice and the final products will be completed. The activities in this section, are organized to meet the achievements proposed for this learning cycle. Students work on different stages of their final product throughout the unit. Then they get ready to work on final details and present it at the end of the unit.

How Am I Doing?

Halfway through the unit, students are invited to reflect on what they have learned so far in the unit. This is done by means of short questions or a simple task.

Final Product

Here, learners present their Final Product. They may do a quick revision and adjust some details before presenting it. The presentation of these final products can be carried out individually, in pairs or small groups, depending on the product.

The final products work as an instrument to do a communicative task that focuses on the social practices of the language. It works as input for students to produce and communicate with others, using the language they learned along the unit. At the end, students should be encouraged to keep their work in their portfolios in order to have more evidence of their learning.

Reflection

Students will also carry out a final reflection on their team's collaboration. This is done by means of simple questions.

Self-evaluation

This section of final self-evaluation encourages students to reflect on their learning and achievements throughout the unit.

The Portfolio

Throughout the series, students are encouraged to keep some of their work in a portfolio. This can be a folder that students decorate in the first week of class. You will find this icon  next to activities which could be included in students' portfolios, but you should encourage them to add whatever they like as well.

Use the portfolios as part of the formative evaluation to help students see their progress throughout the year.

Methodology

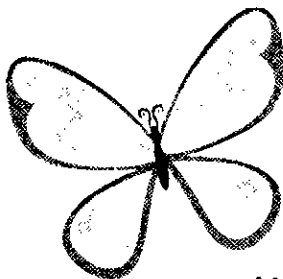

The Whole Child

Humanistic education is concerned with the development of the whole person. Similarly, in a whole language approach, learning is related to all aspects of a child's life, and the different parts of the curriculum are connected and integrated with each other. This helps the child make sense of the world and facilitates learning. It also gives the message that each child deserves respect and is a unique individual. The complementary components and special features of *Yes, We Can!* are designed to aid the child in making connections with other academic areas, as well as consolidating learning and promoting his or her integral development.

Getting Ready for the English Class

It is a good idea to make the English class a special time. You could start each class by saying: *Time for English!* or by playing a game or singing a song. Each class may want to begin with a simple greeting including the time of day: *Good morning. How are you today?*

Then you could talk about the day or the weather. On Mondays, you can talk about what the students did over the weekend. To encourage an English classroom environment, it is advisable to teach formulaic language such as: *Can/May I go to the bathroom? How do you say...in English? Can you repeat that, please?*

As these expressions become more familiar to students, they will become more inclined to use the expressions themselves and more confident when participating in the social practices of language.

The following questioning sequence is recommended to guide students and aid comprehension:

- Begin with a *yes/no* question: *Is today Friday? Is it sunny?*
- Follow with an *either/or* question: *Is it Thursday or Friday? Is it a sunny or a cloudy day?*
- Finally, ask a question that begins with a question word: *What day is it? What is the weather like?*

Materials and Preparation

We suggest that you laminate any materials that you prepare and save them in large labeled envelopes. This will facilitate reusing them whenever necessary. For optimum use, you may also want to lend them to your colleagues.

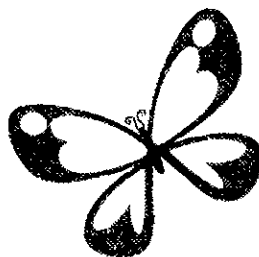

Incorporating Music

Music can be an extremely valuable tool in the classroom. In fact, when young learners listen to classical music, new circuits are created in their brains that can facilitate language acquisition.

As students listen to classical music in the background, you can read short poems or nursery rhymes to them as a relaxing activity. This can be incorporated into a rest time routine.

You can use classical music at the beginning and/or end of each English session, calling out instructions for different movements, such as *Walk/Run/Jump/March* and *Stop and Go*. You can always play popular songs in English and have students dance to them. This is another way of immersing them in the English language. Working with rhythms by themselves can stimulate different areas of the brain as well. You can also practice counting to different rhythms.

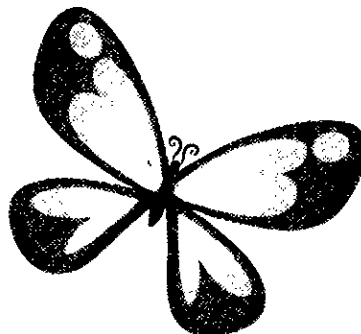

Course Philosophy

Welcome to *Yes, We Can!* — a complete and fun program for teaching English to elementary school students. Its main purpose is to enable students to become competent English users in a pleasurable way. Learners will do what children like to do —role-play, play games, sing and chant, read and enjoy stories and rhymes, listen to stories and music, mime and do hands-on activities. When learning is enjoyable, it is more effective.

Throughout the program, learners actively participate, assimilating the new knowledge into their existing framework and thus making it more meaningful. In other words, students become active constructors or builders of their own knowledge. The child is at the center of the program and the teachers become their guide through the world of English.

Children have a natural desire to learn and communicate. For this reason, students are offered as many opportunities for learning and communication as possible.

The series offers students the opportunity first to listen, read or see models of language, and later to understand concepts and explore language. Young children are still learning basic concepts in their own language, and when those same basic concepts are being acquired and reinforced in a second language, it strengthens their grasp of the concepts themselves, as well as of the new language being learned.

The core idea behind this program is that learning is a process. Therefore, you should not expect your students to master an aspect of language the first time they explore it. Keep in mind this same aspect will be explored again many times throughout the program.

Language is a social construction that needs individual processing. The focus of *Yes, We Can!* is to offer children a balanced program where they can act, interact, collaborate and construct with others, as well as internalize and personalize what they learn. Although at the initial stages the program has a receptive approach, we also encourage production, and this book is built around the cognitive developmental stages of young learners.

Learning a foreign language enriches a child. The child becomes more aware of his or her own mother tongue. Through the foreign language, the child learns that there are other ways to understand people and things. He or she acquires a clearer notion of cultural diversity and tolerance. In particular, by learning English as a foreign language, the child can access a new world of literature and information that complements his or her development and that allows him or her to be in contact with the rest of the world. All this prepares the child to better value and consolidate his or her identity and to respect that of others. The *Yes, We Can!* series was designed to help children become more responsible and truly active global citizens of the 21st century.

The pace of learning in *Yes, We Can!* is not pre-established. We suggest that you adapt the rhythm of the lessons to your students' needs. In this way, it is not necessary to cover one page of the Activity Book in every class.

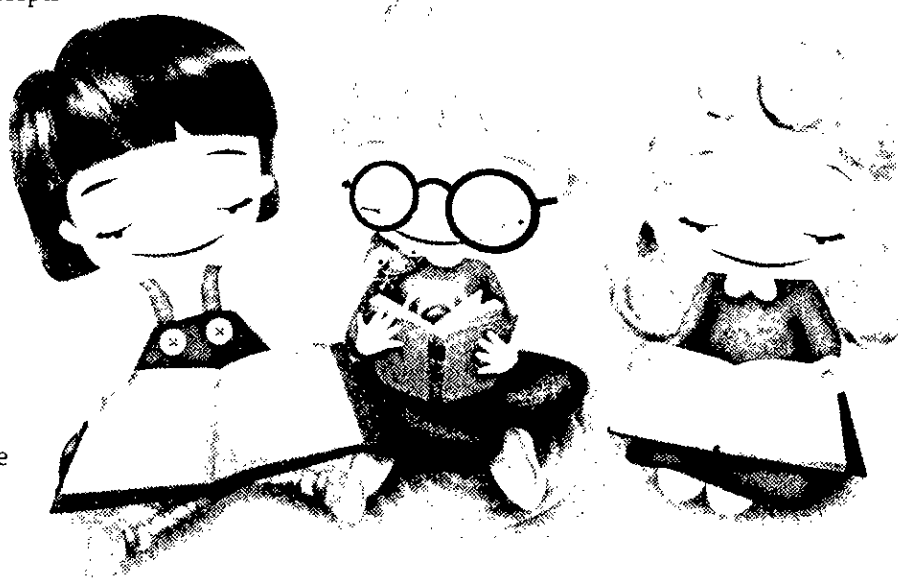

Contents

Course Philosophy	iv
Methodology	v
Course Structure	vi
Icons of the Series	vii
Components	viii
Digital Component	x
Poster Activities	xi
Routine Games and Activities	xii
Scope and Sequence	xiii
Term 1 Unit 1 Let's Make a List of Rules!	T4
Unit 2 Let's Present a Rhyme!	T12
Unit 3 Let's Follow Instructions!	T20
Unit 4 Let's Make Signs!	T28
Term 2 Unit 5 Let's Read Poems!	T36
Unit 6 Let's Make a Questionnaire!	T44
Unit 7 Let's Make a Bar Graph!	T52
Term 3 Unit 8 Let's Make a Hanging Mural!	T60
Unit 9 Let's Make a Chart!	T68
Unit 10 Let's Make a Map!	T76
Audioscripts	T84
Unit Assessments	T90
Term Assessments	T95
Diploma	T101
Bibliography	T103
Glossary	T105

1 Follow and trace to join the words with the elements of the signs.

1. RECYCLE

2. TOILETS



arrow information text arrow
 people
 silhouette

- Listen and repeat.
- Listen to your teacher and point.
- Work with a classmate. Relate the images with the signs from Activity 1. Take turns pointing to each picture and saying the corresponding sign.



Unit 4 29

Achievements

Interpret text in signs to follow instructions. Clarify the meaning of text based on images in signs and their location in public spaces. Point to specific words. Recognize, by their names, some of their features (for example, colors, arrows, people silhouettes, etc.).

Suggested Materials: signs from magazines or for businesses, pictures of signs on construction paper. (Save the signs for use in future lessons.)

Warm Up

We suggest that you cut pictures of signs out of magazines ahead of time and stick them on the board. Students should close their eyes while you take some away. Then they open their eyes and have to say which signs are missing. Put the signs on the board and have students look at them for a minute, then ask students to close their eyes. Take some away and as they open their eyes ask, which are missing.

1 Follow and trace to join the words with the elements of the signs.

We suggest that you start by drawing students' attention to the signs and discuss what they are for with the class. Then you could mention specific elements of the signs.

- T: Point to the arrows in the signs
- T: Point to the figures (people) in the signs.
- T: Point to the words in the signs.
- T: Point to the words in the signs.

Then students should trace the lines from the signs to the words.

► **Listen and repeat.**

You could play Track 11 and have students and listen to the names of the elements in a sign.

► **Listen to your teacher and point.**

Students should listen to you saying the elements of the signs and point to the elements. You could monitor by walking around and checking to make sure students are identifying the features. Help if necessary.

► **Work with a classmate. Relate the images with the signs from Activity 1. Take turns pointing to each picture and saying the corresponding sign.**

Students could form pairs. They should look at the photos and discuss which sign could go with each one.

Wrap Up

If possible make large cards with pictures of signs. Place them around the classroom and give instructions.

T: *It is red and has a word in white.*

Students walk around the classroom until they find the sign.

Answers: ► recycle, toilets



Achievements

Interpret text in signs to follow instructions. Clarify the meaning of text based on images in signs and their location in public spaces.

Suggested Materials Fiction Big Book, soft ball

Warm Up

We suggest playing Color TPR from the Games and Activities section on page xii

2 Label the pictures using the words in the box.

Students should form pairs. We recommend reading the three words in the box and making sure students understand them. It may be necessary to translate to Spanish. Then you could draw their attention to the photos.

Students should write each word under the correct picture.

► Discuss your answers with your classmates and teacher.

We suggest that you check the answers as a class and ask students to explain their answers.

► Color, classify and glue the pictures on Worksheet 4 on page 105. 4

You could have students go to their Worksheet 5 on page 99 then color the illustrations, cut them out and glue them accordingly. It is probably a good idea to emphasize the different use of colors for signs: red, yellow or blue / green.

► Work with a classmate. Point to the pictures, say their meaning and where you can see them.

Students should form pairs and discuss where we would find the signs. For example, we might find the "No Photographs" sign in a museum.

► Final Product Preparation.

We recommend explaining to students that in this unit they will be make a school poster with instructions and signs with the proper elements. They can form teams of three. Then they should go to the Project Template and draw two signs they see on their way home from school.

2 Label the pictures using the words in the box.

Prohibition Direction Warning



- Discuss your answers with your classmates and teacher.
- Color, classify and glue the pictures on Worksheet 4 on page 105.

- Work with a classmate. Point to the pictures, say their meaning and where you can see them.
- In this unit you will make a poster for your school using instructions, signs and their proper elements. Choose two classmates you want to work with. Then go to the Project Template on page 93 and draw two signs you commonly see on your way home. Use the signs from Activity 2 as a model.

30 Unit 4

Wrap Up

Time to read Fiction: Taking a Walk

33

Display page 11 of the Fiction Big Book. Point to and read the title and have students say it after you. Ask students to guess what the story is about and write their ideas on the board. Play Track 33. Turn the pages as the story is told. Check with the class if they guessed right.



Play the track again, stopping after the text on each page. Invite students to come up and point to items and verbs in the pictures and help them to identify the words in the text.



Invite other volunteers to come up and point to the signs and help them to identify the instructions in the text.

Answers: 2 Prohibition, Warning, Direction

3 Complete the instructions with the words in the box.

Don't Exit Be

1. _____ to the right. 
2. _____ take pictures. 
3. _____ careful with the wet paint. 

- ▶ Listen to the audio and point.  12
- ▶ Listen again and repeat.  12

4 Match the instructions with the places where you can see them.



1. Don't ride a bicycle here. 2. Exit to the left. 3. Be careful with the dog.
- ▶ Work with a classmate. Take turns pointing to the pictures above and saying their meaning.
 - ▶ Work with your team from page 30. Go to the Project Template on page 93, complete two more signs and write their instructions.

Unit 4 31

Achievements

Clarify the meaning of text based on images in signs and their location in public spaces. Complete written instructions.

Suggested Materials slips of paper with signs to play Charades

Warm Up

We recommend dividing the class into two teams, preferably of equal size. Divide the slips of paper between the two teams.

A player from Team A draws a phrase slip from Team B's basket. The player acts out the sign and the rest of team has to guess as quickly as possible.

3 Complete the instructions with the words in the box.

We suggest you have students look at the signs and say what they indicate. Then students should use the words in the box to complete the instructions.

Have students work in pairs and look at the signs on the right. Elicit the meanings. Then have students unscramble the words to complete the sentences.

Have them check their answers in groups before you write the them on the board.

▶ Listen to the audio and point.  12

This would be a good time to play Track 12 and have students point to the correct pictures.

▶ Listen again and repeat.  12

We suggest that you play Track 12 again and pause after each sentence so that students can repeat them. Pay special attention to pronunciation.

4 Match the instructions with the places where you can see them.

We suggest that you have students look at the images and elicit the meanings. Then you could read the instructions below match them with the images.

▶ Work with a classmate. Take turns pointing to the pictures above and saying their meaning.

Students should form pairs and practice telling each other what the pictures and signs mean. You could walk around the classroom to check pronunciation.

▶ Final Product Preparation.

Students should get together with the same teams they formed when working on page 30. They should go to the Project Template and draw two more signs. This will help them prepare for their Final Product.

Wrap Up

We suggest playing Pass It On from the Games and Activities section on page xii. You could use the same signs you prepared on page T29 and saved for future use.

Answers: 3 1. Exit, 2. Don't, 3. Be, 4 1. Arrow-arrow-Exit to the left., park-no bicycles-1 Don't ride a bicycle here.; dog-SIGN BEWARE OF DOG-Be careful with the with the dog.

Achievements

Use signs as models to create their own instructions with the purpose of calling to action or inhibition of concrete actions. Give oral instructions for others to follow them. Revise the use of lowercase and capital letters.

Suggested Materials scissors, glue

Warm Up

We suggest that you play a game of Follow the Leader from the Games and Activities section on page xii.

If possible, do actions that are related to signs and students should follow.

5 Match the pictures with the phrases. Discuss your answers with a classmate.

Students should form pairs. We suggest that you draw students' attention to the phrases and the photos of signs. You could point to each sign and ask what they think it means. Then they should match the phrases to the signs. Have students look at the photos and elicit the meanings and places where they can see them. Then ask students to trace the instructions. Encourage students to go to their Picture Dictionary on page 85 and look up the words.

- ▶ **Underline the capital letters in the instructions. Remember that this will help you prepare your Final Product.**

We suggest that you point again to the instructions in Activity 5. Students should underline the capital letters in the instructions. You could ask them why they think those words have capital letters (*They are the first words in the instructions.*) This will help them with their final product.

6 Discuss with your classmates and teacher.

We suggest that you read the questions out loud or invite a student to do it. There are no right or wrong answers, but it is important for all students to participate in the discussion and share their experiences.

▶ Match the pictures with the phrases. Discuss your answers with a classmate.

1. Don't feed the animals.

2. Ramp access.

3. Watch your step



- Underline the capital letters in the instructions. Remember that this will help you prepare your Final Product.

▶ Discuss with your classmates and teacher.

1. Where can you see these signs?
2. Do you see them on your way home?
3. Do you see them at school?
4. Do you commonly see them in your community?

- ▶ Go online and play the game. Then write some of the instructions from the game in your notebook.

32 Unit 4

▶ Final Product Preparation.



For more on signs, go to:

<https://interactivesolutions.co.uk/games/flashGames/safetySigns.htm>

Students should go online and play the game. Then they write some of the game instructions in their notebook. This will help them with their Final Product.

Wrap Up

Time to read! Fiction: Taking a Walk

33

Display page 11 of the Fiction Big Book. Have a student come up and point to the title. Read the story with the class and have them repeat each line after you. Run your finger under the words as you read. Play Track 33. Invite volunteers to the front. With the rest of the class, say the instructions and have the group of students act them out.

Answers: ▶ A 3, B 1, C 2

7 Write the instructions for each sign. Use the instructions in the box.

Don't ride a bike here. Be careful with the wet floor.
Recycle the plastic bottles.



- ▶ Color the frames using the color code.
- ▶ Compare your answers with a classmate. Point to the images and read the instructions.
- ▶ Join with your team from page 30 and choose 2 instructions from Activity 7. Go to the Project Template on page 93, write the instructions and draw their sign.

How Am I Doing?

Reflect about the following questions. Write your answers:

- Can you identify signs and their elements?
- Can you relate signs and the places where you can see them?
- Can you write instructions and draw their signs?

Achievements

Use signs as models to create their own instructions with the purpose of calling to action or inhibition of concrete actions. Write instructions based on a model.

Suggested Materials colored pencils, a piece of white paper

Warm Up

Play Hangman with the verbs from this part of the unit.

7 Write the instructions for each sign. Use the instructions in the box.

We recommend reading the instructions in the box or having a student read them. Students should look at the pictures and choose the instruction that goes best with each picture. Then they write an instruction under each picture.

▶ Color the frames using the color code.

We suggest that you ask students to look at the pictures and identify the places (*supermarket, street / school and schoolyard*). Then they should look at the signs and elicit their meanings. Then draw students' attention to the color code and elicit the meanings of the signs. Finally, ask students to color the picture frames using the colors (yellow, green or red).

▶ Compare your answers with a classmate. Point to the images and read the instructions.

Students should choose a partner. They should take turns pointing to the pictures and reading the instruction out loud to each other. Walk around the classroom helping with pronunciation.

8 Final Product Preparation.

We suggest that you ask students to join their teams. They should choose two instructions from Activity 7 and go to the Project Template. Ask them to write the instructions and draw their sign. This will help them prepare their Final Product.

How Am I Doing?

We recommend reading the questions out loud in class and making sure students understand them. Students should write their answers to the questions. You could ask several students to share their answers with the rest of the class.

Wrap Up

Game: Simon Says

We recommend playing the game Simon Says. Students stand up in their places. Explain that you will give commands but that they should only follow them if you first say *Simon Says*. Start saying commands, increasing the speed as you go. When students make a mistake and follow a command that does not include *Simon Says*, they have to sit down. The last student left standing is the winner.

Answers: 7 1. Don't ride a bike here. 2 Recycle the plastic bottles. 3 Be careful with the wet floor.



Achievements

Use signs as models to create their own instructions with the purpose of calling to action or inhibition of concrete actions.

Warm Up

You could ask students to walk around the school and draw in their notebooks all the signs they see. Then they could work in groups and share their findings.

9 Work with a classmate. Look and draw signs for each place.

You could ask students what places they see in the pictures. Then we suggest that you brainstorm ideas of what rules there are in those public places. Students should draw a sign for each of the places.

► Write the instruction.

Students should write the instruction for the sign they drew in Activity 2.

10 Final Product Preparation.

You could red students that they have seen several examples of signs. It would be a good idea to read the instructions out loud. students should work with their teams and look at their Project Template . Now they should draw a bigger sign on several sheets of paper. Then the should write the meaning of their sign below the drawing and save it for the next lesson.

Wrap Up

Time to read Fiction: Taking a Walk

33

Hold up the Fiction Big Book open to page 11. Play Track 33 and have students raise their hands every time they see a sign. Pause the audio and invite volunteers to come the the front and draw or write the sign on the board. Continue to the end of the story.

Work with a classmate. Look and draw signs for each place.

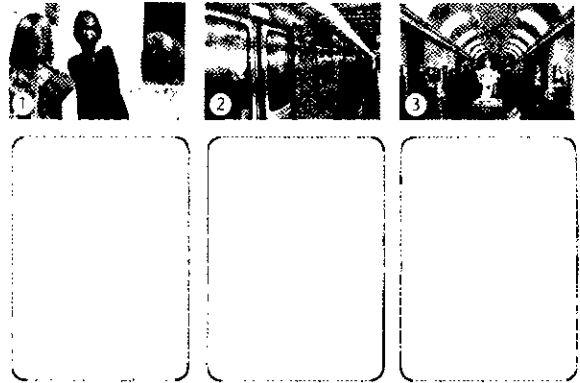

Write the instruction.

- 1.
- 2.
- 3.

Now that you have several examples of signs and their meaning. Follow the instructions.

1. Work with your team from page 31.
2. Look at your your on page 93.
3. Use the signs you did as a model and draw a bigger and final version on different sheets of paper.
4. Write their meaning below the drawings.
5. Keep this work for next lesson.

Final Product

1 Make a poster for your school.

Suggested Materials

- cardboard
- scissors
- glue

Instructions

1. Work with your team to present your poster.
2. Take out the signs and instructions you did on page 34.
3. Glue your signs and instructions on the cardboard to make the poster.
4. Show the signs and read the instructions out loud.
5. Place the poster in a visible space.

Group Reflection

- Did you like working with others to make your poster?
- Did you write the phrases in your poster correctly?
- Did you like sharing your poster with the whole group?

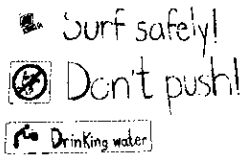

Group Reflection

We suggest you go over the questions and have students discuss in their teams. Then they could share their findings with the class.

Self-evaluation

Students should best answer for them. They should reflect on what they learned in this part of the unit.

Evaluation

Photocopy the Evaluation Instrument: Assessment Rubric on page 35b (1 per student) and complete it for every student according to their performance.

Self-evaluation

Discuss with your team the following aspects of your Final Product and circle your answers.

- I can interpret signs and identify their elements. Yes. No
- I can write instructions for different signs. Yes. No
- I can relate places and the signs I can see there. Yes. No.

Achievements

Write instructions. Reflection and self-evaluation.

Suggested Materials Fiction Big Book

Final Product

1 Make a poster for your school.

Instructions

We recommend having students work with their same teams to present their Final Product. We suggest that they take out their signs and instructions from page 34 and glue them on cardboard to make the poster.

Read out loud and explain the steps. Allow students time to decide on an area of the school they would like to make the poster or ad for. Have students think of 6 signs that will help them at school or use the ones in the template by coloring them. Let students think about how they would like to present it. Have them illustrate the poster and write the instructions.

Monitor the activity and provide as much help as needed. They should present their poster to the class and display it in a visible place.

Term 1

Product Template

Order Stage

FORM 1

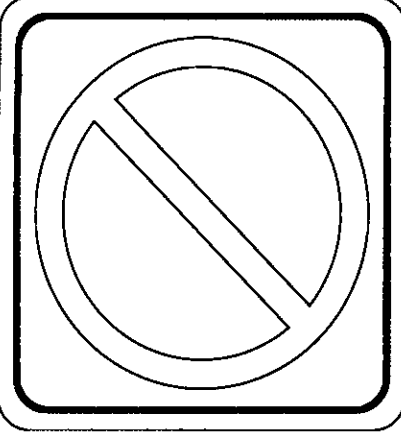
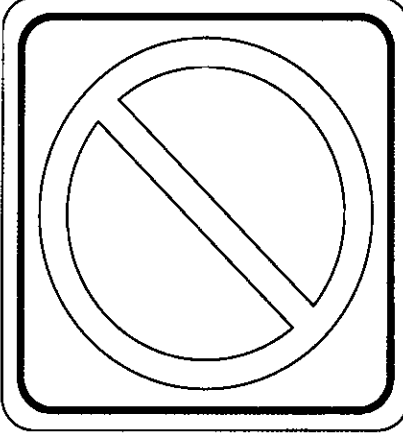
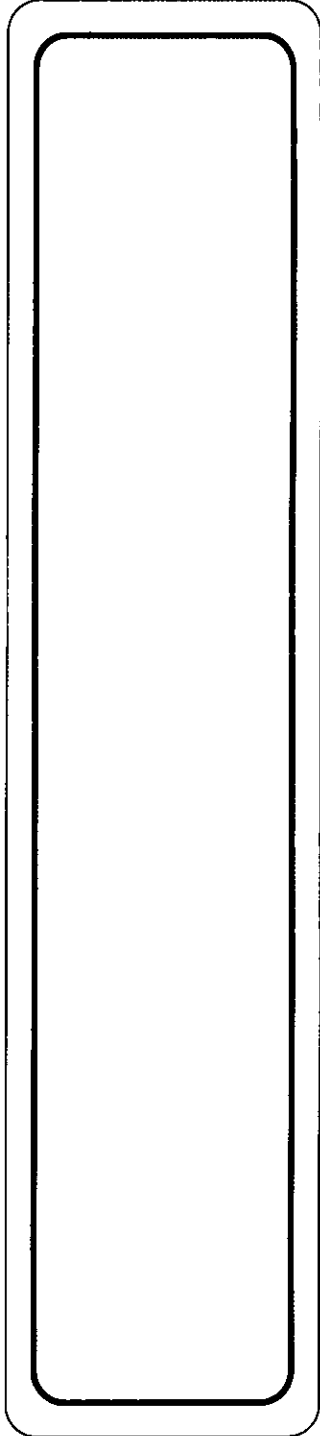
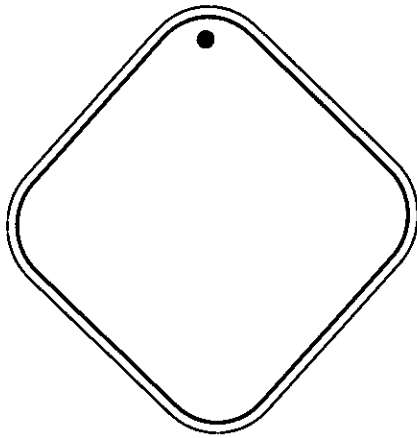
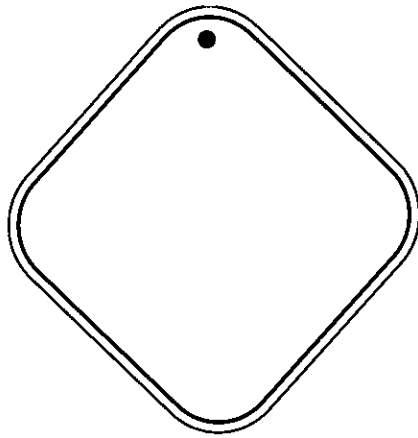
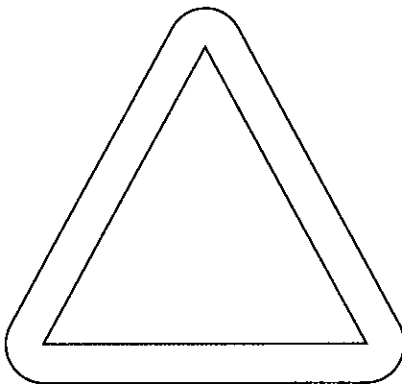
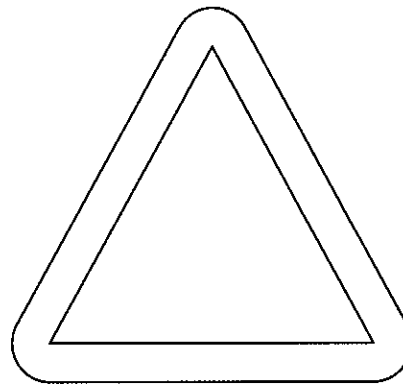
Evaluation Instrument

Unit 4

Assessment Rubric

1 The following assessment rubric can be used to assess your students. Write the number of the descriptor that best matches your student's performance on the score column. Add up the different numbers and check the overall grading scale below.

Name: _____

Date: _____

	5 Can almost always perform the activities correctly, easily and rapidly	4 Can generally perform the activities correctly and with some ease	3 Can frequently perform the activities correctly despite minor difficulties	2 Can sometimes perform the activities correctly but with some difficulty	1 Can rarely perform the activities correctly and with lots of difficulty	SCORE
Aspect To Be Assessed	- Recognize topic, purpose and intended audience of signs.					
	- Recognize, by their names, some of their features.					
	- Interpret text on signs to follow instructions.					
	- Give oral instructions for others to follow them.					
	- Complete and compare instructions.					
	- Point at specific words and review the use of capital letters.					
TOTAL						

GRADING SCALE

- 0 – 12 points: Does not meet standard desired
- 13 – 18 points: Pass though needs improvement
- 19 – 24 points: Pass with a few areas for development
- 25 – 30 points: Pass with very few areas for development

Picture Dictionary

Signs



ramp

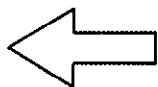

left



prohibition



feed



right



warning



step



paint



direction



bicycle



toilet



dog

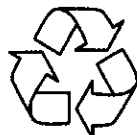

recycle

Unit 4

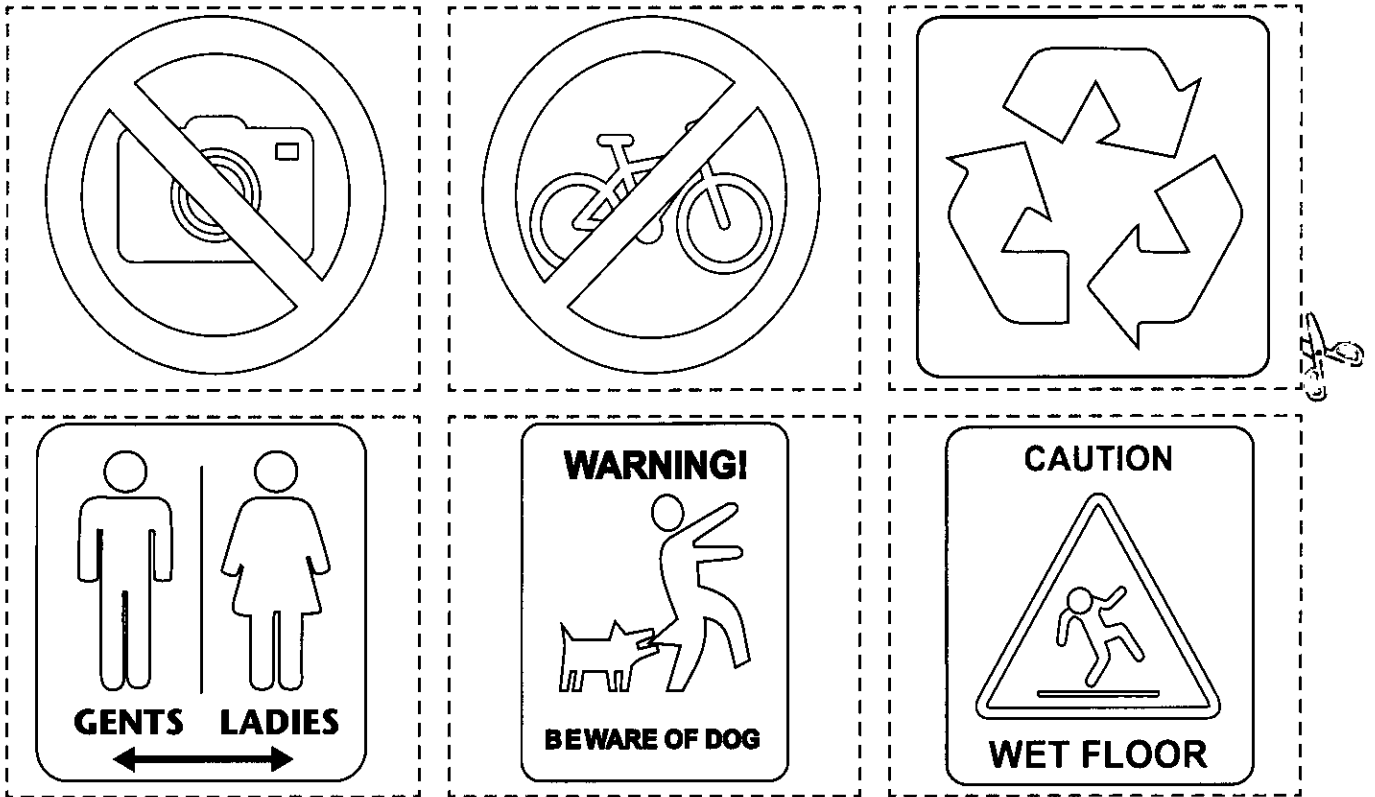

Unit 5

Let's Read Poems!

Curricular Objectives

- (A) Recreational expression
- (B) Change verses in a children's poem.

Environment Literary and ludic

Final Product Illustrated verses of a poem.

Big Book The Noisy, Busy Farm

Achievements

Activate previous knowledge to predict topic and purpose. Recognize graphic and textual components. Distinguish rhyming words.

Warm Up

You could repeat one of the rhymes from Unit 2 that the students enjoyed. Have them join in.

Let's Discover

1 Read the pairs of words out loud.

We recommend having students form pairs. They should name as many objects in the picture as possible. They could use their Picture Dictionaries on page 86 to find some. Elicit the names. Then students read the pairs of words.

► Answer the questions as a class.

We suggest that you read and explain the questions to the class. Elicit their ideas about the unit and encourage them to refer back to Unit 2.

Let's Discover

We recommend reading the questions together in class. Then students color the correct circles to answer the questions on their own.

Poster

We suggest you display Poster 5 at this time. You could do the Create a Poster activity from the Poster Activities on page xi.

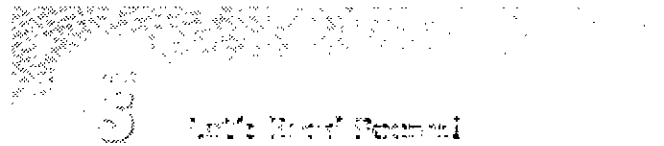

Environment: Family and Community

- Read the pairs of words out loud.
- Answer the questions as a class.

1 Read the pairs of words out loud.

► Answer the questions as a class.

1. Why are the words connected?
2. Are they similar or different?
3. What do you think this unit is about?
4. Do you like poems?
5. Do you know any poems in your language or in English?

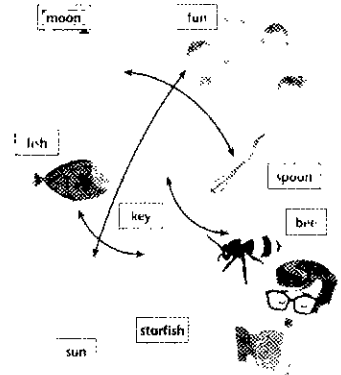

Let's Discover

Color your answers.

1. Do you read poems? Yes No
2. Do you understand poems? Yes No
3. Can you recognize parts of poems and word analysis? Yes No

Wrap Up

We suggest writing the following words on the board in random order: moon, fun, fish, key, spoon, sun, starfish, bee. You could add more rhyming words from Unit 2. Then say one out loud and have students say a word that rhymes. Repeat until you have used all of the words.

Answers: ► 1. Because they rhyme. 2. They are similar. 3. It is about poems. 4. and 5. Answers will vary.

Poster 5

1 Work with a classmate. Take turns reading the poem out loud.



My favorite number is seven
 My favorite color is blue
 My favorite class is science
 My favorite person is you.

Elizabeth Domoney



Read the poem again and complete.

Title:

Author:

Rhyming words:

and

Topic: My



house



family



favorite things

Change the verses of the poem by completing it with your own words.

My favorite number is
 My favorite color is
 My favorite class is
 My favorite person is you.

Elizabeth Domoney

Read your poem out loud to a classmate. Then answer the question.

1. Are your poems similar?

Achievements

Recognize graphic and textual components.
 Sensitize your students for them to value the creative function of language.

Suggested Materials Fiction Big Book, scissors, glue, colored pencils

Warm Up

You could write the alphabet on the board and ask students to read the letters out loud.

Then circle the letter "B" and explain that they are going to find the other letters that rhyme with "B": C, D, E, G, P, T, V, Z. First, you could draw a line to the letter "C" and invite students to come to the board and continue the activity.

Development

1 Work with a classmate. Take turns reading the poem out loud.

We suggest that you read the poem out loud a couple of times. Then students can join in. Several volunteers could also read the poem for the class.

Read the poem again and complete.

Students should complete the information based on the poem. It would be a good idea to explain that the three pictures with their labels are three options to choose from for the topic. Tell them to compare their answers in pairs before checking together as a class.

Change the verses of the poem by completing it with your own words.

We recommend asking students to say what their favorite numbers, colors and classes are and write them on the board. You could also ask for a few words that rhyme with each number: one-sun, run, three-tree, see. Then students should change the verses to make a new poem about themselves to share with the class.

Read your poem out loud to a classmate. Then answer the question.

We recommend having students choose a partner and take turns reading their poems to each other. Then they should say if their poems are similar or not.

Wrap Up

Time to read Fiction: The Noisy, Busy Farm

Display page 23 of the Fiction Big Book. Point to and read the title. Have students say it after you:

T: *The Noisy, Busy Farm.*

Read the story with the class. Point to the characters and the locations on each page and have students identify and describe them:

T: *What are these animals?*

S: *They're the ducks.*

T: *Who's this?*

S: *It's the farmer.*

Use the pictures to present key vocabulary: *farm*.

Answers: ▶ Title: My Favorite Number is seven ...; Author: Elizabeth Domoney; Rhyming words: blue, you; Topic: My favorite things

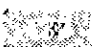

Achievements

Recognize graphic and textual components (verses, stanzas). Discover the meaning of words. Differentiate stanzas from verses. Distinguish rhyming words. Rewrite words in verses and stanzas.

Suggested Materials paper (1 per student), colored pencils, tape, a big drawing or pictures from magazines of each of the following: crab, fish, octopus, starfish

Warm Up

We suggest that you draw some waves on the board and elicit the word *sea*. Elicit some animals students can see in the sea.

You could hold up each of the pictures from magazines as you name the animal, and have students repeat the name after you. The pictures can be displayed around the classroom.

Students should draw any one of the animals, then run to the corresponding wall with their picture.

2 Listen and point. 13

Before playing the track we recommend saying the names of the sea creatures and having students point to their pictures. Then you could play Track 13 and have students listen and point to the creature being mentioned. Encourage students to look up words in their Picture Dictionary on page 86.

► Answer the questions.

We recommend that you remind students of the meaning of *verse*: a line of writing in a poem. and *stanza*: a division of a poem consisting of a series of lines arranged together.

They should answer the questions in their book. They could compare their answers in pairs before checking together as a class.

► Look at the underlined words in the stanza.

Change them to write a new stanza in your notebook. Use the pictures to help you choose the new words.

We suggest that you draw students' attention to the drawings and read the names of the animals out loud. A student could read the stanza out loud and say which words are underlined. Students should write a new stanza in their notebooks using one of the animals instead of fish.

3 Listen and point. 13



Look in the sea.
What can you see?
I see a crab.
And the crab sees me.



Look in the sea.
What can you see?
I see a fish.
And the fish sees me.

Look in the sea.

What can you see?
I see an octopus.
And the octopus sees me.



Look in the sea.
What can you see?
I see a starfish.

And the starfish sees me.



By Elizabeth Domoney

► Answer the questions.

1. How many stanzas?
2. How many verses per stanza?
3. Which words rhyme? _____ and _____

- Look at the underlined words in the stanza. Change them to write a new stanza in your notebook. Use the pictures to help you choose the new words.

LOOK IN THE SEA.
What can you see?
I see a fish.
And the fish sees me.



DOLPHIN



SEAL



TURTLE

- Read your new stanza to a classmate and compare.

38 Unit 5

► Read your new stanza to a classmate and compare.

Student should choose partners and take turns sharing their stanzas with each other. Then they can compare their stanzas.

Wrap Up

We suggest that you have students play Fruit Bowl Upset from the Games and Activities on page xii. But you could substitute the names of fruits for names of animals that live in the sea. Instead of saying Fruit Bowl upset you could say Fishbowl upset.

Answers: ► 1. Four, 2. Four, 3. sea, see, me



3 Draw and circle.

This is me
My hair is *brown / black / blond / red*
It is *short / long* and *curly / wavy / straight*
My eyes are *brown / green / blue*.

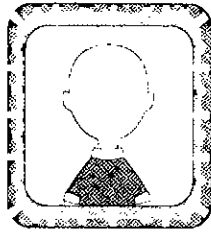

4 Listen and imitate your teacher.

14
I can see
you are
long short
early straight
I look nice both
I am
Eyes are brown
green blue
Yes special, it is
you!



Practice reading the poem aloud.

Go online and read more poems. Choose one you like and write it in your notebook and keep it.

5 You have read several poems now. Go to the Project Template on page 94 and complete Activity 1.

Unit 5 39

Achievements

Recognize words in verses. Recognize changes in intonation. Motivate students to value ludic purposes of language. Sensitize your students for them to value the creative function of language.

Suggested Materials a mirror, colored pencils

Warm Up

Look at yourself in the mirror. Point to and describe the type and color of your hair out loud:

T: *My hair is straight and brown.*

Do the same with the color of your eyes:

T: *My eyes are blue.*

Give the mirror to a student. Help him/her talk about the color of his/her eyes and hair. Repeat with several students. Encourage your students to use their Picture Dictionaries.

3 Draw and circle.

You could point to the frame and ask students to draw themselves in it.

Then read the description while students circle their information. They could look up words in their Picture Dictionaries on page 86.

4 Listen and imitate your teacher.

We suggest that you look for magazine cutouts of people with the features mentioned in the poem ahead of time. Then you could play Track 14 and invite students to follow along in their books. Play the track again and point to the features as they are mentioned: *long, short, curly, straight, brown, green, blue*. Repeat and ask different students to come to the front and imitate you.

Play the track several times, inviting students to join in. Repeat without the track, reading slowly and emphasizing the stressed words.

Practice reading the poem aloud.

You could lead students in reading the text out loud, stressing the words that are in bold font.

We recommend dividing the class into pairs and have them practice reading the poem to each other.



For more on poems, go to

www.storyit.com/Classics/JustPoems/

You could suggest to students that they can find more poems online. They should choose one they like and write it in their notebook to keep for their Final Product.

5 Final Product Preparation.

Students have already read several poems in this unit. They should go to the Project Template on page 43a and write the titles of the poems they have read so far in Activity 1. This will help them prepare for the Final Product.

Wrap Up

We recommend playing Jack Is in the Kitchen from the Games and Activities on page xii.



Achievements

Distinguish rhyming words.
Revise the separation of words in writing.
Practice spelling of rhyming words.

Suggested Materials Fiction Big Book

Warm Up

We suggest repeating the Mother Goose rhyme "Five Little Monkeys":

*Five little monkeys jumping on the bed,
One fell off and bumped his head.
Mama called the Doctor and the Doctor said,
"No more monkeys jumping on the bed!"*

Repeat with four, three and two. Then:

*One little monkey jumping on the bed,
He fell off and bumped his head.*

*Mama called the Doctor and the Doctor said,
"Put those monkeys straight to bed!"*

You could repeat and invite students to act it out.

6 Listen to your teacher say the words and repeat.

We suggest that you read the words out loud first. Then read them again and have the students repeat after you. You could do this several times while walking around the classroom to check pronunciation.

► Write the words that rhyme.

We recommend having students form pairs for this activity. The pairs should find and write the words that rhyme from Activity 6. The first one is done for them.

► Listen and check.

You could play Track 15 and have students check their answers. Then check them by writing all the answers on the board.

► Use the words that rhyme to complete the verses.

You could have students continue working with their partners from the previous activity. We suggest that you read the rhymes pausing at the end of each one. Student should use the words from Activity 6 to complete the rhymes. Then have them share their answers with the class.

Listen to your teacher say the words and repeat.



1. shoe

2. moon

3. sun

4. three



5. town



6. bee



7. blue

8. cat



9. hat

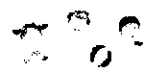

10. fun



11. clown

12. spoon

► Write the words that rhyme.

- | | | |
|---------|------|----|
| 1. shoe | blue | 2. |
| 3. | | 4. |
| 5. | | 6. |

► Listen and check.

► Use the words that rhyme to complete the verses.

I always have fun

I saw a small bee

When I see the

next to a big

I bought a new hat

for my little

40 Unit 5

Wrap Up

Time to read Fiction: The Noisy, Busy Farm 34

Display page 23 of the Fiction Big Book.

Have individual students come up and point to the title of the story. Flip through the pages. Point to the characters and items on the pages to check comprehension:

T: *What are these?*

S: *They are pigs.*

Play Track 34. Turn the pages as the story is told.

Explain to the children that **The Noisy, Busy Farm** is a poem. Ask them how they can tell that it is a poem:

T: *Why do you think that this is a poem?*

S: *Because the last words of the lines rhyme.*

Play the track again and have them pay special attention to the rhyming words.

Answers: ► 1. shoe, blue, 2. moon, spoon, 3. sun, fun, 4. three, bee, 5. town, clown, 6. cat, hat

7 Trace the words.

- Listen to your teacher and complete the poem with the words above.

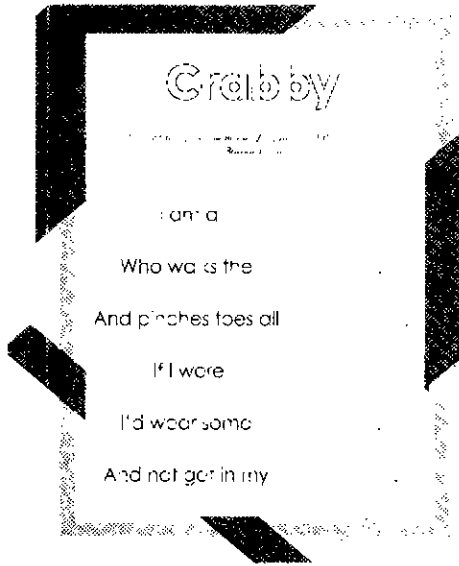

- Illustrate the poem.
- ▶ Circle the words that rhyme.

Unit 5 41

Achievements

Compare the writing of verses based on indicators. Choose an option of a word to complete written verses.

Suggested Materials Fiction Big Book paper, scissors, glue, colored pencils

Warm Up

You could ask students to remember the poem The Noisy, Busy Farm in the Big Book. We recommend presenting another rhyme about living on a farm. You could write this on the board, then say it out loud and have students repeat after you. You could call on two students to come to the board and circle the rhyming words.

THE BOY IN THE BARN

A little boy went, into a barn,
And lay down on some hay.
An owl came out, and flew about,
And the little boy ran away.

7 Trace the words.

Students should trace the words. Then you could invite a volunteer to read the words aloud to the class.

- ▶ Listen to your teacher and complete the poem with the words above.

We suggest that you draw students' attention to the poem in the box. They should use the words above to complete the poem.

- ▶ Illustrate the poem.

You could invite students to illustrate the poem on a sheet of paper and display the drawings around the classroom.

- ▶ Circle the words that rhyme.

We suggest that you read the completed poem out loud again. Students should circle the words that rhyme in the poem.

Time to read Fiction: The Noisy, Busy Farm 34

Ask students if they liked the poem. Then play Track 34 again or read the poem aloud. Invite the students to imitate the sounds each animal makes as you read about it.

At the end of the story have them make all of the noises at once.

- Answers:** 7 crab, shore, day, you, shoes, way
▶ you-shoes, day-way

Wrap Up

We recommend cutting pieces of construction paper ahead of time and writing a rhyming word with a marker pen on each one. The words should be large enough to read easily. You could give one card to each student and ask them to hold up their cards. They should walk around the classroom until they find the classmate with the word that rhymes. You could use more than two words that rhyme and have students form groups: *red, bed, said* or *way, hay, day, say*.

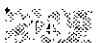

Achievements

Recognize words in verses.

Compare the writing of verses based on indicators (number of words, rhyme, etc.). Choose an option of a word to complete written verses. Rewrite words in verses and stanzas.

Warm Up

We suggest taking students outside and asking them if it is day or night. Ask them how we know it is day. Students should mention everything they can see during the day. Then you could take them back inside. Ask them to cover their eyes and have them tell you what they can see at night.

How Am I Doing?

We recommend reading the question out loud and making sure students understand. Students should circle their answers. You could invite several student to share and explain their answers.

8 Read the poem out loud. Then circle the rhyming words.

We recommend reading the poem out loud first. Then read it again so students can repeat after you. Students should circle the rhyming words. You could check as a class.

► Now draw your friends.

You could invite students to draw a picture of their friends in the box next to the poem.

9 Final Product Preparation.

As an optional activity we suggest doing Worksheet 5 on page 107. This could also be assigned as homework or done in groups. It will help them practice for their Final Product.

Students should read read and color the illustration of the poem on the petals.

Then they should glue the page onto a piece of cardboard and cut out the petals. Finally, they can glue the petals together to form a flower.

You could ask them to present their flower in class and put it in their folder.

How Am I Doing?

Circle your answers.

- | | | | |
|--|------|------------|-----|
| 1. Can you understand poems? | Yes. | Partially. | No. |
| 2. Can you identify rhyming words? | Yes. | Partially. | No. |
| 3. Can you change words of verses in a poem? | Yes. | Partially. | No. |
| 4. Can you illustrate verses of a poem? | Yes. | Partially. | No. |

3 Read the poem out loud. Then circle the rhyming words.

Make New Friends

Make new friends

But keep the old

One is silver

And the others gold.

My Friends

► Now draw your friends.

7 You are going to read and color the illustrations of a poem. Do Worksheet 5 on page 107.

10 You have read more poems now. Go to the on page 94 and finish Activity 1. Then work with a classmate and do Activities 2 and 3.

42 Unit 5

10 Final Product Preparation.

We suggest students go to the Project Template and finish Activity 1 by writing the names of the new poems they have read.

Then you could have them do Activity 2. Students should look back at the poems they have read and find and write the rhyming words. We suggest you help them to get started.

Wrap Up

We recommend repeating the bedtime rhyme. You could translate or explain any new words.

*The Man in the Moon looked out of the moon,
Looked out of the moon and said,*

"'Tis time for all children, on the earth

To think about getting to bed!"

You could repeat the rhyme several times and have students repeat after you. Students should say which two words rhyme: said, bed

Answers: 8 old-gold

Final Product

1 Present your illustrated verses of a poem.

Instructions

1. Take out your illustrated verses.
2. Check that everything is correct.
3. Work with another pair of classmates.
4. Take turns reading your verses of a poem out loud.
5. Show your classmates how you illustrated your work.

clouds

White sheep, white sheep.

On a blue hill.

When the wind stops,

You all stand still.

When the wind blows,

You walk away slow.

White sheep, white sheep.

Where do you go?



Group Reflection

- Did you like the poem?
- Did you enjoy completing verses in a poem?
- Did you like working with a classmate?
- Was it useful?
- How did you illustrate the poem?

Mark (✓) what you can do.

- I can recognize parts of poems and words in verses.
- I can read poems.
- I can complete verses.
- I can change verses in a poem.
- I can illustrate verses.

Self-evaluation

Unit 5 43

Achievements

Presentation of Final Product: an illustrated story.

Reflection and self-evaluation.

Suggested Materials colored paper, cardboard, glue

Final Product

Warm Up

Read the stories "Where's Bobby?" (in the Fiction Big Book), "The Wolf and the Seven Kids" (on page 39) and "Hansel and Gretel" (page 42) to students.

1 Present your illustrated verses of a poem.

Students should work in their groups to present their story. You may ask them to get their materials for their Final Product they did on the previous classes. Help them list the steps involved in creating their presentation, and assign each step to a group. In each group, students all work together to contribute to the class project. Have them discuss how each member can contribute. Distribute cardboard, glue,

colored pencils and other necessary materials and allow the groups to work together.

Finally, ask them to present their stories and show their illustrations to the class. If possible, invite parents or another class to see the students' story presentation.

Group Reflection

You could read the questions out loud and explain their meaning. Have students discuss their answers as a class.

Use the students' feedback to adjust the material, the activities or your teaching style as needed. Emphasize the importance of collaborative teamwork.

Self-evaluation

Read the instructions out loud and make sure students understand their meaning. Have students circle their answers. Encourage them to be honest. You could explain that it is fine if there are some things they can't do. They will learn to do so little by little.

Evaluation

Photocopy the Evaluation Instrument: Control List on page T44b (1 per student) and complete it for every student to record their progress through the unit.

Product Template

Illustration by [unreadable]

Write the titles of the poems you have read so far in the unit.

	Title	Page
Poem 1		
Poem 2		
Poem 3		
Poem 4		
Poem 5		
Other		

- In this unit, there are different poems with rhyming words. Look back at the poems and write the pairs of rhyming words. Look at the example.

blue

you

- Now you are ready to work on your Final Product.

- Choose some rhyming words and write some verses of a poem using these words.
- If you prefer, you can choose one of the poems from Activity 1 of this Template.
- Do this on a separate piece of paper.
- Illustrate your work.
- Keep your work to present it at the end of the unit.

POEM 2

Self-Evaluation

1 The following self-evaluation sheet can be used to assess your students. Have students read the statements and cross out the face that best fits how they feel about their abilities.

Name: _____

Date: _____

I can understand poems.	<input type="radio"/>	<input type="radio"/>	<input type="radio"/>	<input type="radio"/>
I can recognize parts of poems and words in verses.	<input type="radio"/>	<input type="radio"/>	<input type="radio"/>	<input type="radio"/>
I can relate pictures with verses.	<input type="radio"/>	<input type="radio"/>	<input type="radio"/>	<input type="radio"/>
I can identify stanzas and verses.	<input type="radio"/>	<input type="radio"/>	<input type="radio"/>	<input type="radio"/>
I can identify rhyming words.	<input type="radio"/>	<input type="radio"/>	<input type="radio"/>	<input type="radio"/>
I can read poems.	<input type="radio"/>	<input type="radio"/>	<input type="radio"/>	<input type="radio"/>
I can write verses.	<input type="radio"/>	<input type="radio"/>	<input type="radio"/>	<input type="radio"/>

Picture Dictionary

Unit 5

Sea Creatures

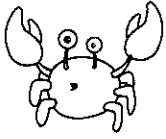

crab

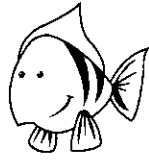

fish



octopus



starfish

Physical Characteristics



short



long



curly



wavy



straight

Night or Day

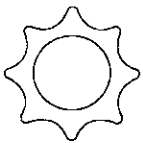

sun



moon

The lion and the unicorn



Were fighting for the crown

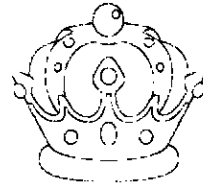

The lion beat the unicorn



All around the town.

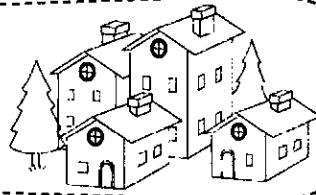

Some gave them white bread,

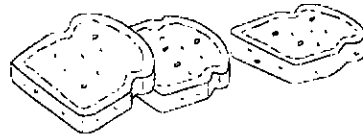

And some gave them brown.

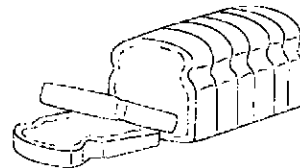

Some gave them plum cake

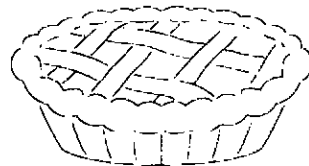

and drummed them out of town.

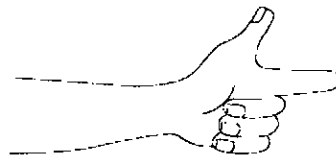

Unit 6

Let's Make a Questionnaire!

Curricular Objectives

- (A) Search and selection of information.
- (B) Write questions for information on agricultural products.

Environment Academic and educational

Final Product Questionnaire to get information on fruits and vegetables.

Big Book All About Fruits and Vegetables

Achievements

Explore illustrated children's books about agricultural products. Participate in the exchange of questions and answers on agricultural products. Review writing questions to get information.

Suggested Materials a soft ball, plastic fruits and vegetables

Warm Up

To start the unit, we recommend introducing the concept of food and asking students what their favorite foods are. You could draw a sandwich, a bowl of soup, a glass of milk, a chicken leg, a banana and a carrot on the board.

Write f-o-o-d below the pictures and read the word out loud for students to repeat. Point to each picture and ask:

T: *Is this food?*

Throw the ball to a student and ask him/her to name his/her favorite food. Continue with all the class.

Let's Circulate!

1 Look and circle the fruits and vegetables.

Students look at the picture and circle ten fruits and vegetables. Then they close their book and tell a partner what they found. Students need to know that fruits and vegetables are natural products from agriculture. They could also name other natural products that they are familiar with and write a list on the board.



Let's Make a Questionnaire!

Time Out!

Environment: Academic and educational

Curricular Objectives

- (A) Search and selection of information.
- (B) Write questions for information on agricultural products.

Environment Academic and educational

Final Product Questionnaire to get information on fruits and vegetables.

Big Book All About Fruits and Vegetables

Achievements

Explore illustrated children's books about agricultural products. Participate in the exchange of questions and answers on agricultural products. Review writing questions to get information.

Suggested Materials a soft ball, plastic fruits and vegetables

Warm Up

To start the unit, we recommend introducing the concept of food and asking students what their favorite foods are. You could draw a sandwich, a bowl of soup, a glass of milk, a chicken leg, a banana and a carrot on the board.

Write f-o-o-d below the pictures and read the word out loud for students to repeat. Point to each picture and ask:

T: *Is this food?*

Throw the ball to a student and ask him/her to name his/her favorite food. Continue with all the class.

Let's Circulate!

1 Look and circle the fruits and vegetables.

Students look at the picture and circle ten fruits and vegetables. Then they close their book and tell a partner what they found. Students need to know that fruits and vegetables are natural products from agriculture. They could also name other natural products that they are familiar with and write a list on the board.

How Much Do I Know?

Students should discuss the objectives for the unit as a class, saying how they think they can achieve them.

Poster

Display Poster 6 and do the Place in Alphabetical Order game from page xiii to work with it.

Wrap Up

Students play a game of Pass It On! page xii. If possible, instead of classroom supplies, use plastic fruit and vegetables.

Answers: 1 carrot, grapes, onion, banana, lettuce, strawberry, pineapple, broccoli, mushroom

1 Look and circle the fruits and vegetables.

Discuss the questions with a classmate.

1. What is your favorite fruit?
2. What is your favorite vegetable?
3. Where do fruits and vegetables come from?
4. Where can you find information about them?

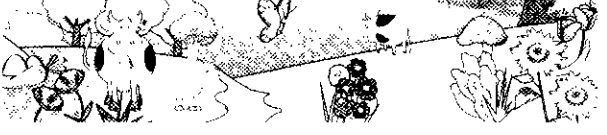

How Much Do I Know?
Discuss these questions with a classmate.

- Can you distinguish parts of a book? Which are these? Can you identify characteristics of fruits and vegetables? Write some on your notebook.
- Can you ask and answer questions about fruits and vegetables?

► Discuss the questions with a classmate.

Read the questions out loud and explain their meaning to the class. Students discuss their answers in pairs before a class discussion.

How Much Do I Know?

- Students should discuss the objectives for the unit as a class, saying how they think they can achieve them.

Poster

Display Poster 6 and do the Place in Alphabetical Order game from page xiii to work with it.

Wrap Up

Students play a game of Pass It On! page xii. If possible, instead of classroom supplies, use plastic fruit and vegetables.

Answers: 1 carrot, grapes, onion, banana, lettuce, strawberry, pineapple, broccoli, mushroom

1 Look and answer with a classmate.



1. What is this book about?
2. How do you know?
3. Is this book for children or for adults?
4. Where can you find more about fruits and vegetables?

2 Look and label.

cover title contents page back cover

All About Fruits and Vegetables



Read and trace the arrows.

title

A Fruit or a Vegetable?
Fruits are developed from a flower. Fruits have seeds inside or sometimes outside. Most fruits are sweet.

paragraph

A vegetable is a part of a plant that we eat. Flowers, stems, leaves or roots. Vegetables do not contain seeds and they are not usually sweet.



illustration

Achievements

Anticipate content from previous knowledge and illustrations. Distinguish cover, title, contents page and back cover. Determine purpose and intended audience. Identify links between text and some graphic resources. Detect components of the text.

Suggested Materials Nonfiction Big Book, magazines or brochures about fruits and vegetables, scissors, glue

Warm Up

To begin the class, students could review fruits and vegetables that they already know in a chain game. The chain starts with: When I go to the market, I buy... Students take turns recalling the chain so far and adding another item until somebody forgets and the chain starts again.

1 Look and answer with a classmate.

In pairs, students ask and answer the questions. Then students can ask and answer the questions in front of the class.

2 Look and label.

Students need to know that the words in the box are for parts of a book, and the illustrations below are of those same parts. You could model the pronunciation of the words for students to repeat first. Students then work alone to label the illustrations.

Read and trace the arrows.

This activity is also to practice parts of a text. You could model the pronunciation of the words for students to repeat first. Students should then trace over the arrows to link the parts of the text with the examples.

Wrap Up

Time to read Nonfiction: All About Fruits and Vegetables

Ask students what it is and elicit the word book. Ask them if they like reading books and why.

Display the Nonfiction Big Book on page 21. Have a volunteer point to the first page and help him/her read the title.

Ask the class what kind of information they can find there.

Draw two columns of the board and write the headings: Fruits, Vegetables. Ask students to name as many fruits and vegetables as they can and write them in the correct column. Accept answers in Spanish.

Answers: 2 title, cover, contents page, back cover

UNIT 6

Achievements

Identify characteristics of agricultural products.

Suggested Materials Nonfiction Big Book, construction paper (1 sheet), paper (1 sheet per student)

Warm Up

Time to read Nonfiction: All About Fruits and Vegetables 29

Hold up the Big Book and play Track 29. Draw another chart on the board with two columns: *Fruits* and *Vegetables*. Invite students to repeat the activity and ask them if they can now name more fruits and vegetables in English.

3 Look and match.

Students read the words in the boxes out loud and draw lines to match them with the pictures of fruits and vegetables. They should look up words in the Picture Dictionary on page 87.

4 Work with a classmate. Look at the fruits and vegetables in the box and take turns saying their characteristics. Look at the examples.

Students need to know what each of the words means first. They should look them up in the Picture Dictionary and then discuss them one by one, substituting the correct information into the sentences in the speech bubbles. You could elicit several examples and then allow students to continue in pairs. Students could also write five or so sentences at the end in their notebook.

5 Final Product Preparation.

Students turn to the Product Template on page 51a and draw one fruit or vegetable for each of the six characteristics in Activity 4. They may continue the work on a sheet of paper if they cannot fit the items on the template.

Wrap Up

Students could collaborate to create a class chart of fruits and vegetables on a sheet of construction paper. They can draw each fruit or vegetable and list its characteristics below. They can add other fruits and vegetables and their characteristics to the chart as they come across them in the unit.

1 Look and match.

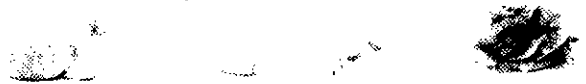

4 Work with a classmate. Look at the fruits and vegetables in the box and take turns saying their characteristics. Look at the examples.

peas grapes celery green beans grapefruit
guava pear apple lemon corn pumpkin spinach
carrot potato watermelon broccoli onion banana

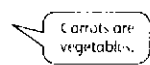
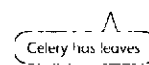
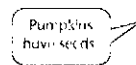

5 In this unit you will write a questionnaire to get information on fruits and vegetables. Go to the ... on page 95 and do Activity 1.

46 Unit 6

Answers: 3 flowers—cauliflower; seeds—guava, pumpkin, watermelon; fruit—guava, watermelon; leaves—celery, spinach; stems—celery; root—carrot, potato 4 Fruits: grapes, grapefruit, guava, pear, apple, lemon, banana, watermelon; Vegetables: peas, celery, green beans, corn, pumpkin, spinach, carrot, potato, broccoli, onion

6 Look at the picture of the orange and circle the correct options below.

1. Color: yellow / orange 2. Shape: round / long
3. Taste: sweet / salty 4. Size: big / small

7 Look at the pictures and read the dialogues.



Is the orange yellow?

No, it isn't.



Are oranges big?

Yes, they are.



Are oranges round?

Yes, they are.



Are oranges sweet?

Yes, they are.



Are oranges soft?

No, they aren't.



Go to Worksheet 6 on page 109. Use the pictures and ideas to practice more dialogues with a classmate.

Achievements

Understand questions about agricultural products. Answer closed questions using a model. Identify characteristics of agricultural products when listening to them.

Suggested Materials Nonfiction Big Book

Warm Up

Students will practice forming closed questions with the verb *to be* in this lesson. They could review the form and meaning of the questions and short answers by unscrambling and then asking and answering some simple questions: *Are / you / a / student?*, *Is / it / Friday / today?*, *Is / your teacher's / name / Jackie?*, *Am / I / nine years old?*

At the end, you could elicit or point out that the verb comes before the subject in this type of question.

6 Look at the picture of the orange and circle the correct options below.

Review the list of characteristics with the class and explain their meaning if necessary. Then students

look at the photo of the orange and mark its characteristics.

7 Look at the pictures and read the dialogues.

The dialogue between the boy and the girl is about the characteristics of oranges. The specifics of the dialogue can easily be changed to talk about other fruits. First, you could read each speech bubble out loud for students to repeat, then practice the dialogue with a strong student, and finally allow students to practice alone before they practice with a partner.

Final Product Preparation.

Students are going to practice the same dialogue but this time substituting other fruits for oranges. They can take turns asking and answering. Stronger pairs may be able to ask and answer without looking back at the dialogue. Volunteer pairs can perform one of the dialogues for the class at the end.

Wrap Up

Students add the fruits they have seen in this class to the chart of characteristics they started on page 46.

Time to read Nonfiction: All About Fruits and Vegetables

Ask students to give their opinion about fruits and vegetables:

T: *Do all fruits taste the same? Which do you prefer? Why?*

Read the story with the class by reading each line of the text and having the class repeat. Run your finger under the words as you read. Go back to page 24 and invite some students to come up and point to different colored fruits and vegetables: T: *Point to a yellow fruit.*

Ask other volunteers to point to different characteristics on the other pages: shape, size, texture and taste: T: *Point to a sour fruit.*

Answers: 6 1. orange, 2. round, 3. sweet, 4. small

Achievements

Understand questions about agricultural products. Answer questions about characteristics of agricultural products. Answer closed questions using a model.

Suggested Materials a variety of fruits and vegetables with different shapes and textures, scissors, glue

Warm Up

Students sit in a circle. Walk behind students touching their heads as you name the same fruit or vegetable:

T: *Broccoli, broccoli, broccoli.*

Name a different fruit or vegetable as you touch the next student's head:

T: *Cucumber.*

Ask this student to stand up and start running around the circle in the opposite direction to yourself. Run around the circle and try to sit in the student's empty place before he/she does. The person left without a seat starts touching heads and naming a fruit or a vegetable again.

8 Look at the pictures and circle the correct answer.

Students will continue their practice of closed questions with the verb *to be* in this lesson. You could model each question for the class to repeat before they start the activity, making sure they understand the new words for characteristics: *sour* and *hard*. Students read the questions and answer options by themselves and circle the correct ones.

► Practice the questions with a classmate.

A strong pair could demonstrate the activity first for the class. Then pairs continue. They could also ask about other characteristics of these fruits and vegetables at the end.

9 Mark (✓) the correct option

Students need to understand the new characteristics in the table before they work alone to mark the correct answers.

► Practice the questions and answers with a classmate.

Students work with their same partner to ask and answer. They should check each other's answers at the same time.

Look at the pictures and circle the correct answer.

Are pears blue?
Yes, they are.
No, they aren't.

Are corn cobs big?
Yes, they are.
No, they aren't.

Are potatoes blue?
Yes, they are.
No, they aren't.



Is broccoli hard?
Yes, it is.
No, it's not.



Are limes sour?
Yes, they are.
No, they aren't.

► Practice the questions with a classmate.

► Mark (✓) the correct option.

1. Are limes green?
2. Are apples square?
3. Are potatoes small?
4. Are pears smooth?
5. Are grapes sweet?

► Practice the questions and answers with a classmate.

► Go to the _____ on page 95 and do Activity 2.

48

10 Final Product Preparation.

Students should work alone to choose one fruit and one vegetable—ones they have seen so far or another of their choice—and complete the chart with their characteristics.

Wrap Up

Students could add any new fruits and vegetables to their class chart.

Answers: 8 No, they aren't. No, they aren't. No, they aren't. No, it's not. Yes, they are. 9 1. Yes, they are. 2. No, they aren't. 3. No, they aren't. 4 Yes, they are. 5. Yes, they are.

11 Read the dialogue and practice it with a classmate.

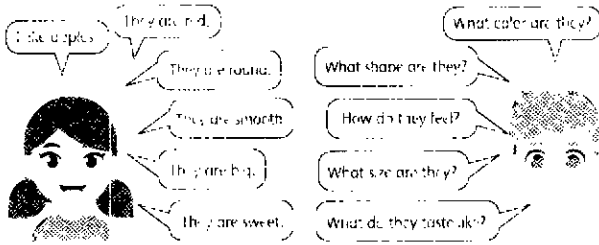

12 Unscramble the questions about carrots.

- | | |
|----------------------------------|--|
| 1. color / What / are / they / ? | 4. do / How / feel / they / ? |
| They are orange. | They feel bumpy. |
| 2. What / are / they / size / ? | 5. taste / do / like / they / What / ? |
| They are small. | They taste sweet. |
| 3. they / shape / are / What / ? | |
| They are triangular. | |

• You have learned different questions, now go to the **Product Template** on page 95 and do Activity 3.

<ul style="list-style-type: none"> • I can identify a fruit or vegetable. • I can identify color, size, flavor and shapes of fruits or vegetables. • I can identify a vegetable, fruit and vegetable. 	<p>Yes / I need practice / No</p> <p>Yes / I need practice / No</p> <p>Yes / I need practice / No</p>
--	---

Achievements

Identify question words and question mark. Organize words to form questions. Complete question models to get information. Answer closed questions using a model. Invite children to take care of resource materials.

Suggested Materials paper (2 sheets per student), colored pencils, safety pins

Warm Up

Students each draw a fruit or a vegetable on a piece of paper. There should be equal numbers of each fruit or vegetable. Students then pin their drawings onto their clothes, put their chairs in a circle and sit down. A volunteer stands up.

Name a fruit and a vegetable:

T: *Guavas and potatoes.*

Students with the drawings of the fruit and the vegetable you mentioned exchange seats.

The standing student has to sit down on a temporarily free chair while they are exchanging seats. The student who loses his/her chair is left standing for the next round.

11 Read the dialogue and practice it with a classmate.

You could read through the speech bubbles one by one for students to repeat and practice. They may need some help to realize the order of questions and answers. The students can practice with a partner.

12 Unscramble the questions about carrots.

Students write the words in the correct order to form questions. When finished, they compare in pairs. Check on the board. Students identify the question words (*What, How*) and the word order that questions follow.

Students identify the question marks and have them circle them. Check answers in the class.

► Final Product Preparation.

Students turn to the Product Template on page 95 and complete Activity 3. They should choose a fruit or vegetable and write five open or closed questions about it and their answers. They can check each other's work in pairs once they finish.

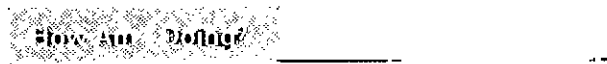

Go through the questions as a class and then allow students a minute to answer for themselves. You could check students' answers and provide extra practice of the different skills as necessary.

Wrap Up

Students could each ask another student about one of the characteristics of the fruit or vegetable that they chose for Activity 3 on their Product Template. This can be done as a whole-class activity so that everyone can hear and correct the question or answer as necessary.

Answers: 12 1. What color are they? 2. What size are they? 3. What shape are they? 4. How do they feel? 5. What do they taste like?

Achievements

Rewrite answers of closed questions. Understand questions about agricultural products. Answer questions about characteristics of agricultural products.

Suggested Materials Nonfiction Big Book, paper (1 sheet per student), magazines with pictures of fruits and vegetables, scissors, glue

Warm Up

Students could play a game of twenty questions to guess fruits and vegetables. They can only ask closed questions: *Is it a fruit? Is it red? Is it sweet?* The student who correctly guesses the fruit or vegetable takes the next turn.

13 Read and complete. Then guess the fruit or vegetable.

Write on the board questions to ask for the different characteristics of a fruit or a vegetable:

T: *What color is it? Is it big or small? What shape is it? What does it taste like? How does it feel?*

Name each characteristic and ask different volunteers to point to the corresponding question.

Read the words in the boxes out loud. Students complete the riddles using the words and the questions on the board as a reference. The last line has to be answered with the name of the fruit or vegetables they think they are talking about. Then students discuss their answers with their partners.

Ask students about the occasion when they ask questions:

T: *Do you ask questions if you know the answer?*

Ask them who they ask questions of:

T: *Do you ask your mother/father/friend/teacher questions?*

14 Final Product Preparation.

Students will write their questionnaire for the Final Product in this activity. They should work with a partner to go through the instructions, asking for clarification if necessary, and write their questionnaire on a sheet of paper. They can decorate their questionnaire with drawings or pictures cut out from magazines.



For more on fruits and vegetables, go to:
www.healthykids.nsw.gov.au/kids-teens/eat-more-fruit-and-vegies-kids.aspx

Students could access the website in class or at home. You could set some questions to focus their reading:

1: Read and complete. Then guess the fruit or vegetable.

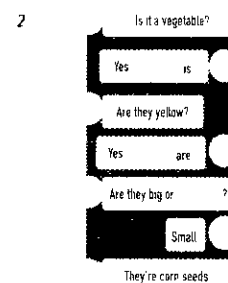
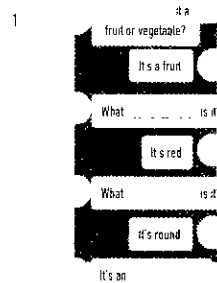

1: Work with a classmate and follow the instructions.

1. Choose a fruit or a vegetable you learned in this unit with a classmate and correct any mistakes.
2. Go to the page on page 95 and use the information you collected to write your questionnaire. Use the questions you wrote as a model.
3. Write your questions and answers in your notebook. Then compare
4. Write your questionnaire on a clean sheet of paper.
5. Illustrate your questionnaire. You can use drawings or cut outs from magazines.
6. Keep your work to present it next class.

For more on fruits and vegetables, go to

50 Unit 6

How much fruit and vegetables should you eat every day? What kinds of fruit and vegetables are there? Fresh, frozen, canned or dried.

Wrap Up

Time to read Nonfiction: All About Fruits and Vegetables

Have a volunteer open the Nonfiction Big Book to the text *All About Fruits and Vegetables* and point to the title. Have him/her go through pages 22 to 28 and ask him/her to point to a question. Read the question out loud and have the class repeat after you. Run your finger under the words as you read.

Ask another volunteer to find the answer in the text. Repeat the rest of the questions with other volunteers.

Answers: 13 1. Is, color, shape, apple 2. it, they, small

1 Present a questionnaire about fruits and vegetables.

Group Reflection

- What fruit or vegetable did you choose?
- Where did you look for the information?
- Was it easy to write the questions and answers?
- Was it easy or difficult to answer your classmates' questions?

Steps

1. Work with your classmate from page 50. Take out the questionnaire you wrote.
2. Get together with another pair of classmates.
3. Take turns asking the questions so your classmates answer them.
4. If possible, work with another pair of classmates to ask the questions again.



Self-evaluation

Mark (✓) your answers.

During the presentation...

- I asked questions clearly.
- I understood my classmates' questions.
- I answered questions easily.

Achievements

Review writing questions to get information.
Reflection and self-evaluation.

Suggested Materials reference books, supermarket brochures, paper, colored pencils, scissors, glue

Warm Up

Students work in the same pairs to review their questionnaire and make any last minute changes. They should check the questions are correctly formed and then practice asking and answering them together.

1 Present a questionnaire about fruits and vegetables.

Pairs work with another pair to ask and answer the questions on their questionnaire. Students should take notes on the answers. If time, pairs can ask another pair their questions for extra practice. Students could report some of their questions and answers at the end.

Group Reflection

Read and explain the questions to the class. In their groups, students discuss the answers and reflect on what they did and how they did it before reporting their answers to the class.

Self-evaluation

Students mark the statements according to how well they think they performed in the Final Product presentation. This activity is for their own personal benefit so they don't have to share their answers.

Evaluation

Photocopy the Evaluation Instrument: Comparison List on page T51b (1 per student) and answer it according to your students' individual performances.

Wrap Up

Students display their surveys in the classroom. They walk around in pairs reading the surveys and asking and answering the questions.



Product Template

Draw the fruits and vegetables you learned on page 46 and write the words you learned about their characteristics. You will use some of these words in your Final Product.

Characteristics of fruits and vegetables

Choose one fruit and one vegetable. Write their characteristics below. You will use some of these words in your Final Product.

	Fruit _____	Vegetable _____
Color		
Size		
Shape		
Texture		
Taste		

You have learned different questions in this unit. Choose a fruit or a vegetable, write five questions and answer them. You will use these questions in your Final Product.

Fruit or vegetable: _____

1. _____
2. _____
3. _____
4. _____
5. _____

1 The following comparison list can be used to assess students. Mark the column that best fits students' performance for each descriptor on the list. After completion check the grading scale below.

Name: _____

Date: _____

Aspects To Be Checked	A	B	C
	Can usually perform the activities accurately	Can sometimes perform the activities accurately	Can rarely perform the activities accurately
1 Anticipate content from previous knowledge and illustrations.			
2 Determine purpose and intended audience.			
3 Distinguish components of a text.			
4 Understand questions about agricultural products.			
5 Organize words to form questions.			
6 Answer closed questions using a model.			

- More than 4 aspects have a mark in the A column – Strong pass
- More than 4 aspects have a mark in the B column – Pass
- More than 4 aspects have a mark in the C column – Not satisfactory

Plants

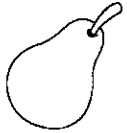

fruit



seed



leaves

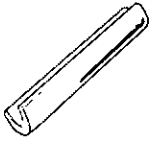

stem

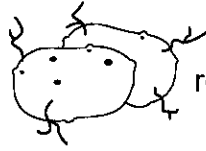

roots



flower

Fruits



apple



banana



grapes



lemon



grapefruit



guava



watermelon



pumpkin



pear

Vegetables



potato

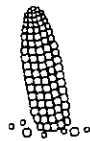

corn

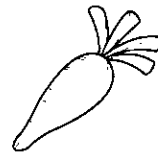

carrot



green
beans



cauliflower



spinach



peas



broccoli

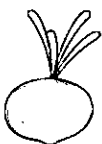

onion



celery

Use the pictures and ideas to practice more dialogues with a classmate. This will help you practice for your Final Product.



celery/round



grapes/big



carrots/long



bananas/sweet



spinach/soft



Let's Make a Bar Graph!

Curricular Objectives

- (A) Exchanges associated with information of oneself and of others.
- (B) Exchange information on personal data.

Environment Family and community

Final Product Information about hobbies for an illustrated graphic.

Big Book Collections

Achievements

Activate previous knowledge.

Suggested Materials paper, colored pencils

Warm Up

We suggest having students draw a picture of what they do after school.

Students should form groups and share their pictures with their groups. The groups should decide which picture they like best.

Let's Circle Our Favorite

1 Look and circle your favorite activity.

Students should look at the photos and circle their favorite activity.

Ask them if their activity is popular in the place where they live. You could ask them which activities they think are the most popular among boys and girls their age. You could point out that there are a lot of different free-time activities.

It is a good idea to encourage students to look up words in their Picture Dictionary.

> Answer the questions.

We recommend reading the questions out loud and clearing up any doubts. Students should choose a partner and share their answers. Questions 1 and 2 are about the pictures and questions 3 and 4 are personal.

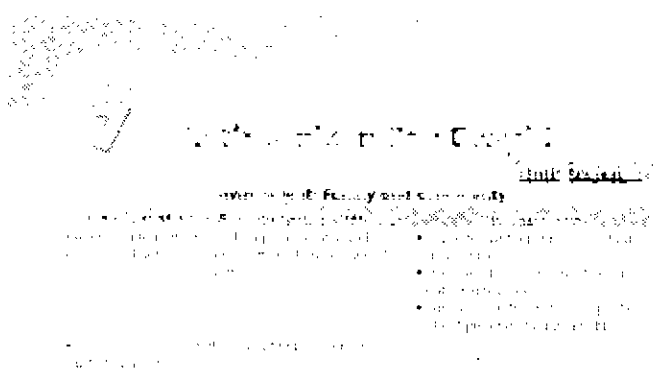

Look and circle your favorite activity.

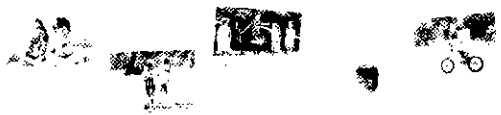

Answer the questions.

1. Where are the people?
2. What are they doing?
3. What do you do in your free time?
4. Do you have a hobby?

Mark (✓) your answers:

Mark (✓) your answers:	Yes	No
Can you do these hobbies?		
Do you circle and underline all the personal information and hobbies?		
Can you ask an English question about hobbies?		
Can you understand the answers about hobbies?		

How Much Do You Know?

We suggest that you read the list of questions out loud and make sure that students understand them. Then they should mark the Yes or No box to answer each question about themselves.

Poster

this might be a good time to display Poster 7 and do Choose an Item from the Poster Activities on page xi. We recommend changing it to Choose an Activity. You could say the following activities: *a boy and girl playing soccer, a boy painting, a boy standing on his head, a woman looking in a window, a robot reading a book, two boys dancing, a woman drawing, a boy walking down the street*

Wrap Up

You could write a list of free-time activities on the board and then explain the meaning of the words outdoors (al aire libre) and indoors (adentro de la casa). Students decide if each activity is usually done indoors or outdoors.

1 Listen to the audio and number. 16



When is your birthday?
 R-I-C-K-Y
 How do you spell your name?
 It's on August 1st.
 What's your name?
 Ricky.
 I'm eight.
 How old are you?



On March 21st.
 When is your birthday, Gloria?
 G-L-O-R-I-A
 How do you spell your name?
 What is your name?
 How old are you?
 Gloria
 I'm seven.

2 Look and sing along! 17

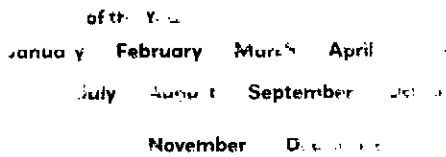

2 Practice asking and answering questions with a classmate. You can use questions from Activity 1 as a model.

• Now, repeat the activity with a different classmate.

Achievements

Identify their own and others' personal data when listening. Recognize the writing of names and graphics of numbers used to express ages. Spell proper names. Link a list of personal data with classmates.

Suggested Materials a soft ball

Warm Up

We suggest you pass out slips of paper and have students write their birthday and favorite hobbies but to exclude their name. You could pick up the papers and put them in a hat. Ask students one at a time to pull a paper out of the hat and read it out loud. The rest try to guess who it is.



1 Listen to the audio and number. 16

We suggest you point to the pictures of the students and introduce them: *Ricky and Gloria*. Then play Track 16 and have them order both conversations and check their predictions. You could explain that we use ordinal numbers to say the date of our birthdays.

► Look and sing along! 17

We recommend having students look at the months of the year and eliciting what these words are. Play Track 17. Students should sing along as they point to the months of the year.

You could reflect with students on the similarities of the months in English and the months in Spanish. Point to February.

T: *What's this month in Spanish? Are they similar or different?*

2 Practice asking and answering question with a classmate. You can use questions from Activity 1 as a model.

To personalize the information, you could ask students to answer these questions. First, do it orally and then ask them to write them down. Then students should form pairs and share their personal information with their partner.

► Now, repeat the activity with a different classmate.

We suggest that students change partners and share their personal information with another classmate.

Wrap Up

You suggest that you have students sit in a circle and explain that you are going to play a game with the months of the year. Start off by saying *January* and toss the soft ball to another student who has to say the following month, *February*. He/she then tosses the ball to another who must say the next month. Continue in the same way until December and start over again.

Answers: 1 1, 7, 4, 3, 8, 1, 2, 6, 5
 2. 6, 5, 4, 3, 1, 7, 2, 8

300002

Achievements

Associate pictures of hobbies with a brief description. Clarify the meaning of words with the help of an illustrated bilingual dictionary. Recognize names of hobbies when listening to them.

Suggested Materials Nonfiction Big Book

Warm Up

We suggest that you play Guess the Hobby. You could divide the class into teams. Give a brief description of the hobby or activity and invite the students to guess what the hobby is. You could use the activities presented on this page. The first student to guess correctly wins a point for their team.

T: *You do it on something with two wheels. You do it to go from one place to another.*

S: *Ride a bike*

Before the Book

3 Look and label.

We suggest that you draw students' attention to the pictures and ask what the children are doing. Students should use their Picture Dictionary to label the pictures.

Check answers as a class.

► Listen and write R (Ricky) or G (Gloria).

We suggest that you play Track 18. A woman is asking Ricky and Gloria what they like to do. Students should listen and write R or G in the boxes in Activity 3 that show the things they each like to do.

Check as a class.

4 Ask four different classmates about their hobbies. You can use the vocabulary from Activity 3.

First, we suggest that you ask if students know what a hobby is: something you do regularly in your free time. Explain that there are many different kinds of hobbies. You could read the speech bubbles out loud or ask a student to read them. Students should interview four different classmates and ask them about their hobbies.

Answers: 3 read, watch TV, ride a bike, play video games, draw, swim, climb trees, knit, play soccer, dance ballet, play the violin, play with toys

► R: watch TV, play video games G: knit, ride a bike
4 first, second, third, fourth, fifth, sixth, ninth, tenth, eleventh, twelfth, twenty-first

Look and label.



Listen and write R (Ricky) or G (Gloria).

Ask four different classmates about their hobbies. You can use the vocabulary from Activity 3.

What do you do in your free time?



I like to ride my bike.

Classmate 1:

Classmate 2:

Classmate 3:

Classmate 4:

54

Time to read Nonfiction: Collections

30

Before referring students to the Big Book, ask them about their hobbies. Encourage them to tell you what they like doing in their free time.

Display pages 29 to 38 of the Nonfiction Big Book.

Explain to students that collecting things is a very popular hobby. Point to the objects on the pages and help students identify their names:

T: *Are these toys? Which ones?*

Ask students what the text is going to be about and write some of their ideas on the board.

Play Track 30 and turn the pages as the story is told.

Check with the class if they guessed correctly.

Play the track again, pausing after the text on each page. Invite students to come up and point to items in the pictures. Help them identify the words in the text: *teddy bears* (p. 31), *coins* (p. 32), *Vinyl records* (p. 33), *vases* (p. 34), *old bottles* (p. 35), *shells* (p. 36).

5 Go to Worksheet 7 on page 111 and complete it with the information about hobbies you have learned so far.

6 Listen to the audio and complete. 19

question answer

• Role-play the conversations with a classmate.

Go to: and play the game to learn more new vocabulary about free time activities.

Unit 7 55

Achievements

Answer and answer, with help, questions about personal data. Recognize composition of questions about hobbies and personal data.

Warm Up

You could divide the class into two teams. We suggest that you write the first letter of each month of the year on the board in no particular order. You could to each letter and, in turns, have student from each team name a month that begins with that letter. Write out the complete words.

The winning team is the one that gets the most correct months.

5 Final Product Preparation. 7

We recommend doing Worksheet 7 at this time. This will help students practice for their final product.

6 Listen to the audio and complete. 19

We suggest that you play Track 19 and have students point to the conversations as they hear them. Students should write a question mark if the sentence is a

question, or a period if it is an answer. You could check the answers as a class.

► Role-play the conversations with a classmate.

Students should form pairs and role-play each of the conversations using their books. After they have practices saying the convrsations several times, volunteers role-play the conversations in front of the class without using their books.



For more free-time activities go to: www.harrykindergartenmusic.com/song/204

Students should go to the website to play the game to lean more new vocabulary about free time activities. This will help them complete their Final Product.

Wrap Up

You could write a form on the board and ask students to copy it in their notebook. Leave the form on the board for now.

Name: _____

Age: _____

Free time activities:

1. _____

2. _____

Students should ask the classmate to their right and write down the information. encourage them to use complete sentences.

S1: What is your name?

S2: My name is ...

On the board write the answers and tally then to see how many have the same hobbies, etc.

Answers: 5 1 ?, . / 2. ?, . / 3. ?, . / 4. ?, .



Unit 7

Achievements

Recognize composition of questions about hobbies and personal data. Answer, with monosyllables, concrete questions about hobbies. Formulate, based on a model, questions about personal data.

Suggested Materials 1 piece of paper per student, colored pencils, chalk

Warm Up

Each student should draw a picture of a hobby on a piece of paper.

You could take your students outside to the school yard and draw a big Venn diagram on the ground with the words *City* and *Countryside* above each of the circles. All students should be able to step inside.

Then each student should hold up his/her picture and name the hobby. You could help them stand in the correct area, depending on whether the activity is usually associated with the city or countryside, or both.

Explain that if the activity can be done in both, students should stand in the area where the two circles overlap.

7 Complete the questions. Then answer them about you.

We recommend reading the incomplete questions out loud. Students should complete them with the question words from the box. You could complete the questions on the board for students to check.

8 Match the pictures with the sentences.

We suggest that you read the question and have different students read the answers out loud. Students should look at the pictures and draw lines to match the pictures to the answers.

► Final Product Preparation.

We recommend explaining to students that their Final Product in this unit will be a bar graph. They should go to the Project Template and choose hobbies to complete Activity 1

7 Complete the questions. Then answer them about you.

How When What

1. How often do you play with your pet?
2. How often do you play with a ball?
3. When do you play with your toys?
4. What do you like to play with?
5. How often do you draw pictures?

Match the pictures with the sentences.



WHAT DO YOU LIKE TO DO?

- 1. I like to play with my pet.
- 2. I like to play with dolls.
- 3. I like to play with a ball.
- 4. I like to ride my bike.
- 5. I like to draw pictures.



► Go to the Project Template on page 96. Choose hobbies to complete Activity 1.

► Go to the Project Template on page 96. Choose hobbies to complete Activity 1.

56

Wrap Up

You could ask students to name the question words and write them on the board. They give answers and ask students to say if the answer refers to *when*, *what*, *why* or *who*.

T: *On Saturday.*

S: *When*

T: *A big dog*

S: *What*

Answers: 6 1. What, 2. How, 3. When, 4. What, 5. How 7 ride, ride, 2. play, 3. play, 4. draw, 5. play, 6. play

► Left-hand column, from top to bottom: ride my bike, play with a ball, play with toys. Right-hand column, from top to bottom: draw pictures, play with dolls, play with my pet.

7 Read the dialogue with a classmate.



Ask ten classmates about their personal information and hobbies. You can use the dialogue from Activity 4 as a model. Choose hobbies using the words in the box.

video games watching TV painting riding a bike
 swimming playing soccer collecting reading

- 1.
- 2.
- 3.
- 4.
- 5.
- 6.
- 7.
- 8.
- 9.
- 10.

Go to the _____ on page 96. Write the questions and answers to complete Activities 2 and 3.

Unit 7 57

Achievements

Formulate, based on a model, questions about personal data. Complete questions about personal data. Recognize composition of questions about hobbies and personal data. Compare answers related to personal data and hobbies.

Write, based on a model, questions about hobbies.

Suggested Materials Nonfiction Book 1 strip of paper per student, scissors, glue

Warm Up

We suggest having students write the name of their favorite hobby on a strip of paper using their Picture Dictionary if necessary. They should hold up the strips of paper, stand up and find other students with the same hobby. Then they should form groups.

Count the number of students in each group and say to the class:

T: Five students like to play soccer. Two students like to climb trees.

9 Read the dialogue with a classmate.

Read the dialogue out loud. The students should form pairs and read it to each other. Then they could take turns asking and answering the questions but with information about themselves.

Ask ten classmates about their personal information and hobbies. You can use the dialogue from Activity 4 as a model. Choose hobbies using the words in the box.

You could read the names of the hobbies or activities in the box. Students should form groups of ten or walk around the classroom interviewing classmates. They should write down their names and the hobbies or activities they like.

Final Product Preparation.

We suggest that you ask students to go to the Project Template and write the questions and answers to complete Activity 2 and Activity 3.

Wrap Up

Time to read Nonfiction: Collections

30

Open the Big Book to page 33 and read the text. Explain that Maria is interview people she knows about what things they collect as a hobby. Then ask students what question Maria asks and point to it. Play Track 30 and point to the words as the track plays.

Achievements

Produce their own writing of personal data.
Revise the writing of written names and figures of cardinal and ordinal numbers. Invite your students to use their own and others' personal data with responsibility.

Warm Up

Play Hangman with students using the words *birthday*, *hobby* and the names of hobbies from the unit.

You could use the following question so they get ready for Activity 10: *When's your birthday?*

Always, Never, Sometimes

We suggest that you read the statements out loud and make sure they understand them. Students should color the emoticon that they feel is correct for them.

Have students identify different items in the picture:

T: *Point to the paper hats. Point to the balloons.*

Help them to identify the cake:

T: *Is this a birthday cake?*

Write *Happy Birthday!* on the board. Elicit what question goes below the cake.

Ask students to copy it from page 56, or to write it first. Check their writing.

10 Report your findings.

Tell students that they will report the information from the interviews on page 57 in the form of a graph.

Then students write the names of activities under the horizontal axis at the bottom of the graph. Then they count the number of students who like doing each activity up to that number and draw bars using a different color for each of the activities.

Ask volunteers to display their graph and talk about the results.

► Final Product Preparation.

Students should go back to their Project complete the bar graph.



Color the faces according to what you can do.

- I can identify hobbies. 😊 😞
- I can ask and answer questions about personal information and hobbies. 😊 😞
- I can complete questions about personal information and hobbies. 😊 😞

T Report your findings.

10

9

8

7

6

5

4

3

2

1

- Go back to the on page 97 and complete the Bar Graph. Then copy the Bar Graph in a complete sheet of paper.

58

Time to read Nonfiction: Collections

30

Display the Nonfiction Big Book.

Play Track 30, pausing after the text.

Have a student say which question Maria asks: *What do you collect?* Name the character on each page and ask students to complete what the characters collect. Invite different volunteers to come up and point to the corresponding items in the pictures. Ask students if they collect things. T: *Do you collect (bottles)?*

Ask them about their collection. T: *How many (bottles) do you have? What is your favorite (bottle)?*

Wrap Up

We recommend playing How Many Can You Find with classroom objects. Write the names of several classroom object that can be easily seen: *desks, tables, chairs, blackboard*, and so on. You could ask students to copy them in their notebooks. They should walk around the classroom, count the number they see of each object and write it down. In the end, ask students to report their findings.

Final Product

1 Present a Bar Graph.

Instructions

1. Take out your Bar Graph.
2. Practice with a classmate the presentation of your Bar Graph.
3. Present the Bar Graph to your classmates.

Group Reflection

- Was it easy to present your graph?
- Did you like your graph?
- Did you find out new things about your classmates?

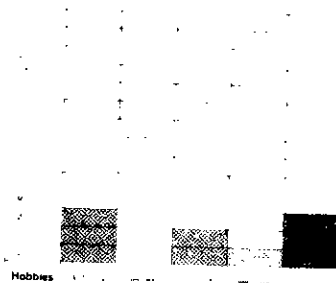

Self evaluation

Color the faces according to what you can do.

- Can you identify hobbies? ☺ ☹
- Can you understand questions about personal information and hobbies? ☺ ☹
- Can you ask and answer questions about hobbies? ☺ ☹
- Can you conduct a survey about hobbies? ☺ ☹

Unit 7 59

Achievements

Get information about hobbies to make an illustrated graph. Reflection and self-evaluation.

Suggested Materials Nonfiction Big Book, paper, colored pencils

Final Product

1 Present a Bar Graph.

Instructions

We recommend reading the instructions out loud. Students should take out their bar graphs. They choose a partner and practice presenting their bar graphs to each other. Then they present them to the rest of the class.

Group Reflection

Read the questions out loud. Students should answer the questions and discuss their answers with their partner.

Self-evaluation

We suggest you read the question out loud. Students should color the emoticon that represents what they

can do after completing the unit. Have students color the faces according to whether or not they achieved the objectives.

Evaluation

Photocopy the Evaluation Instrument: Assessment Questionnaire on page T59b (1 per student) and answer it for every student to keep in their portfolios.

As part of students' summative evaluation, it is a good time to give them Assessment Term 2 on pages T107 and T108.

Assessment Term 2 Answer Key:

- 1 1. octopus, 2. short, 3. day, 4. night, 5. leaves, 6. fruit, 7. read, 8. swim, 9. play video games, 10. ride a bike
2 1. Yes, 2. No, 3. Yes, 4. Yes, 5. Yes, 6. Yes, 7. Yes, 8. No, 9. Yes, 10. Yes

Product Template

Bar Graph

1 Ask your classmates about their favorite hobbies. Prepare your questions below.

1. _____
2. _____
3. _____

2 Now write the answers.

1. _____ Hobby: _____
2. _____ Hobby: _____
3. _____ Hobby: _____
4. _____ Hobby: _____
5. _____ Hobby: _____
6. _____ Hobby: _____
7. _____ Hobby: _____
8. _____ Hobby: _____

3 Complete the Bar Graph with the answers.

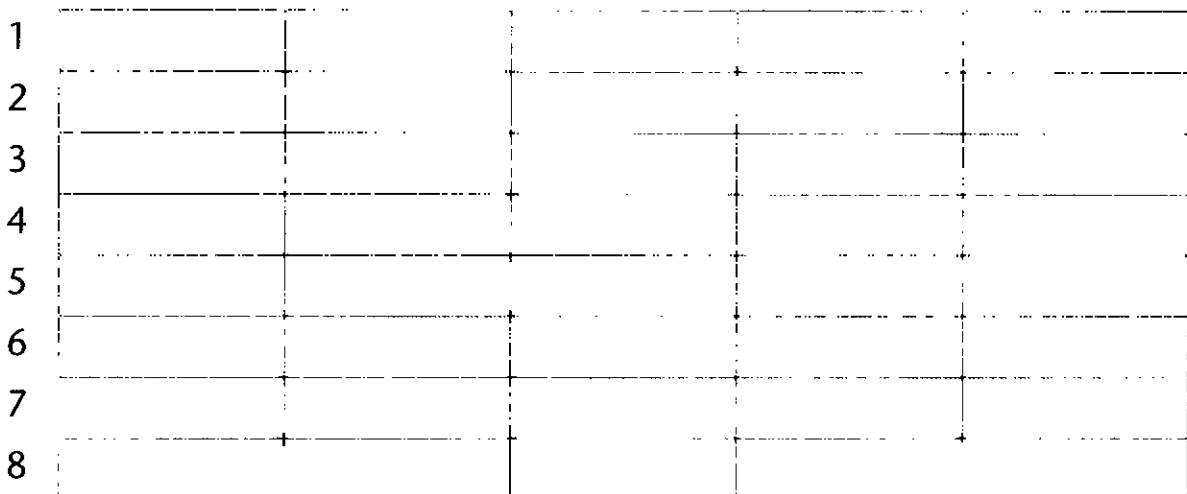

Assessment Questionnaire

1 The following assessment questionnaire can be used to assess students.

Name: _____

Date: _____

	Yes	No
Can the student identify hobbies?		
Can the student understand questions about personal information and hobbies?		
Can the student ask and answer questions about hobbies?		
Can the student conduct a survey about hobbies?		
Can the student compare answers related to personal data and hobbies?		
Can the student use their and other's personal data with responsibility?		

- Between 5 and 6 questions were answered with YES – Strong pass
- Between 3 and 4 questions were answered with YES – Pass
- Between 1 and 2 questions were answered with YES – Not satisfactory

Picture Dictionary

Unit 7

Hobbies

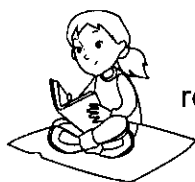

read

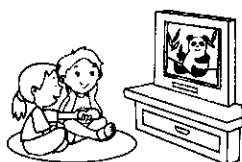

watch T.V.



ride a bike



play
video games



draw



swim



climb



knit



play soccer



do ballet



play violin



jump the rope

24					
23					
22					
21					
20					
19					
18					
17					
16					
15					
14					
13					
12					
11					
10					
9					
8					
7					
6					
5					
4					
3					
2					
1					
Hobbies	Watch TV	Reading	Playing with dolls	Swimming	Painting

Unit 8

Let's Make a Hanging Mural!

Curricular Objectives

- (A) Understanding oneself and others.
- (B) Read stories to compare emotions.

Environment Literary and ludic

Final Product Illustrated sentences related to own experiences for a hanging mural.

Big Book All About Fruits and Vegetables

Achievements

Activate previous knowledge to anticipate topic, purpose and intended audience.

Suggested Materials colored pencils, sheet of write paper.

Warm Up

We recommend saying a feeling and having students make faces or gestures to express them. Call out the feeling again and have them draw it on a sheet of paper. Repeat with other feelings.

Unit Overview

1 Look and draw a happy or a bored face.

We suggest that you draw a happy face and a bored face (yawning, with its mouth open) on the board. You could help students identify each mood:

T: *Is he bored? Is he happy?*

Students should look at the picture on page 60. You could ask them what the boy is doing and whether or not he is happy or bored:

T: *Is the boy happy or bored?*

Ask them to complete the face in order to make the boy look either bored or happy.

► Answer the questions.

Students should groups of four and look at the picture. They should read the questions and discuss them in their groups. Everyone may have different answers to



Let's Make a Hanging Mural!

Unit 8

Environment: Literary and ludic

Final Product Illustrated sentences related to own experiences for a hanging mural.

Big Book All About Fruits and Vegetables

How Much Do I Know?

Circle your answers.

Can you identify different parts of a book?	Yes	Sometimes	No
Do you recognize characters when you read stories?	Yes	Sometimes	No
Can you express emotions when you read stories?	Yes	Sometimes	No
Can you write about your emotions?	Yes	Sometimes	No

Poster

Display Poster 8. We recommend using Make Up a Story from the Poster Activities on page xi. You could use the four pictures of the ducks instead of the markers.

Wrap Up

We suggest that you play Follow the Leader with the students. You can find the instructions in the Games and Activities on page xii.

How Much Do I Know?

Circle your answers.

1. What is the boy doing?
2. Do you usually read stories?
3. What do you like reading? Fairy tales, mystery stories, fiction stories, etc?

questions 2 and 3. You could ask for a show of hands to find out the most popular genres of stories.

How Much Do I Know?

It is a good idea to go over the questions with the students and make sure they understand them. Students should then read the questions again and answer them on their own.

Poster

Display Poster 8. We recommend using Make Up a Story from the Poster Activities on page xi. You could use the four pictures of the ducks instead of the markers.

Wrap Up

We suggest that you play Follow the Leader with the students. You can find the instructions in the Games and Activities on page xii.

Development

1 Look and answer.



1. What's the title of the story?
2. Who's the author?
3. Is this a fiction or a nonfiction story?
4. Who are the main characters?
5. Is this story for children or for parents?
6. What page is it?

2 In this unit you will write sentences about your experiences and emotions when reading stories. Read and circle the answers below.

- | | | | | |
|--------------------------------------|-------|-----|-------|-------|
| 1. Romantic stories make me feel... | bored | sad | happy | angry |
| 2. Funny stories make me feel... | bored | sad | happy | angry |
| 3. Fairy tales make me feel... | bored | sad | happy | angry |
| 4. Mystery stories make me feel... | bored | sad | happy | angry |
| 5. Adventure stories make me feel... | bored | sad | happy | angry |

• Compare your answers with a classmate.

▶ Go to the Fiction Big Book on page 97 and do Activity 1.

Achievements

Identify the parts of a book. Identify target audiences. Recognize graphic and textual components. Provide your students with clues so that they can understand the function of tales in society.

Suggested Materials Fiction Big Book, 1 sheet of paper per student, colored pencils

Development

1 Look and answer.

Students should form pairs. Point to the cover of the book. Then you could read the questions out loud and explain what they mean. Students discuss their answers in their groups. Check the answers as a class.

2 Final Product Preparation.

You could explain to students that they should write about their emotions when reading stories. Students should read and circle their answers on their own. This will help them prepare for their Final Product.

▶ Compare your answers with a classmate.

Students should form pairs and compare their answers.

3 Final Product Preparation.

We suggest doing Activity 1 of the Product Template. You could ask students to turn to page 97. They should write in the box the words they have learned to express their feelings. This will help them prepare for the Final Product.

Time to read Fiction: The Frog Prince



Open the Fiction Big Book to page 29. Read the title and point to the picture. Ask students if they think the story is fiction or nonfiction and why. Then ask what they think the story is about.

T: *Is the story about a princess? Is it about a frog?*

Point to the princess and the frog and explain that they are the characters in the story. Write the word *Characters* on the board.

Play Track 35. Turn the pages of the story as it is told. Check with the class if they guessed right.

Wrap Up

We suggest that you play the Color TPR from the Games and Activities section on page xii. As an added feature you could ask students how the different colors make them feel.

Answers: 1 1. The Frog Prince, 2. José del Astillero, 3. Fiction, 4. The frog and the princess, 5. For children, 6. 29

Achievements

Detect the structure of a text (beginning, climax and ending). Identify the parts of a book
Look up the meaning of words in an illustrated dictionary. Recognize characters by their names.
Suggested Materials Fiction Big Book

Warm Up

We suggest that you play Fruit Bowl Upset from the Games and Activities section on page xii. You could make a list of fruits on the board to help them.

3 Look and answer.

You could read the first question and have students look at pictures 1, 2 and 3 and say what is wrong.

Then they should look at pictures 4 and 5 and say what the rabbits are doing. Students continue answering questions.

Encourage them to look up any new vocabulary in their Picture Dictionary on page 88.

► Work with a classmate. Choose one character each and read the story out loud.

Students should form pairs and each choose a character. Then they should practice reading the story out loud. You could invite several pairs to read the story to the class.

► Discuss the questions with your classmate.

You could ask students to remain in pairs and read and discuss the questions. If time permits, several pairs could share how the story made them feel with the rest of the class.

3 Look and answer.

1. Look at Pictures 1, 2 and 3. What is the problem?
2. Look at Pictures 4 and 5. What are the rabbits doing?
3. What happens in the end?
4. Who are the main characters? Where are they?

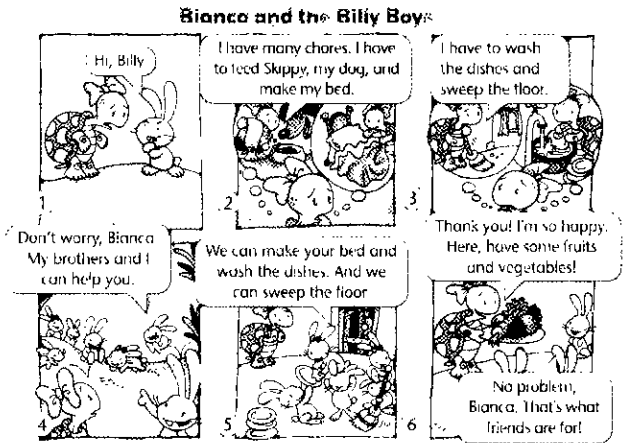

► Work with a classmate. Choose one character each and read the story out loud.

► Discuss the questions with your classmate.

1. Did you like the story?
2. How does it make you feel, happy, sad, angry?
3. Are the characters good friends? How do you know?

62 Unit 8

Wrap Up

Time to read Fiction: The Frog Prince 35

Go to pages 30 and 38 of the Fiction Big Book. Play Track 35 and turn the pages as the track plays. Then ask volunteers to retell the beginning and end of the story. Have different volunteers retell the story using the pictures.

Point to the characters and items and help students identify who the main characters are:

T: *Is the princess a character? Is the table a character?*

- Answers:** 3 1. The problem is that they can't find the pet.
2. They are looking for the tarantula.
3. They find the tarantula.
4. Tommy, the tarantula, the boys; They are in a house.

4 Read and circle the feelings. Then compare with a classmate.



Pixon Kay lives in the Caribbean Sea. Today he's happy! Mary and who's are visiting him. Dolphins are very friendly. Look, Pixon Kay is jumping!



When it starts raining, Pixon Kay gets sad. The boat is going away. He's crying.



While swimming, he sees something getting closer. What's that?



Oh! It's a shark! Pixon Kay is very scared.



Surprise! It's Naia, his friend. She's always joking around. Pixon Kay is really angry this time!

Read the story again. Then mark (✓) the sentences about what you think of the story.

- | | | | |
|---------------------------------|--------------------------|-----------------------------------|--------------------------|
| 1. What a nice story! | <input type="checkbox"/> | 4. What a funny friend! | <input type="checkbox"/> |
| 2. It's a funny story. | <input type="checkbox"/> | 5. The story makes me feel angry. | <input type="checkbox"/> |
| 3. I think the story is boring. | <input type="checkbox"/> | 6. I didn't like the story. | <input type="checkbox"/> |

Go to the Project Template on page 97 and do Activity 2.

How Am I Doing?

Mark (✓) what you can do.

I can express emotions.

I can use expressions to give my opinion.

I can recognize characters in stories.

Achievements

Compare actions and emotions of characters.
Express emotions about actions and characters as the text is being read to them.

Suggested Materials 1 sheet of paper per student, scissors, glue

Warm Up

Ask students to draw one of the following items on a piece of paper: a fruit, a ball or a storybook. Have three volunteers hold up different drawings and elicit an action associated with the item (eat, play with a ball, read).

Write *School Yard*, *Bathroom* and *Classroom* on the board. Ask students to stand (with their drawing) under the heading of the place in school where they can do their action. Check with the class if they are correct:

T: *Can you play with a ball in the classroom?*

Point out that some actions can be done in more than one place.

4 Read and circle the feelings. Then compare with a classmate.

We recommend reading the texts below the drawings out loud. Ask students to follow along in their books. Then you could read the again and tell students to raise their hands when they hear a feelings word. Then explain to students that they should circle the feelings. Finally, they should form pairs and check their answers.

► Read the story again. Then mark (✓) the sentences about what you think of the story.

We suggested that you read the statements out loud to make sure students understand them. Then students should answer on their own.

5 Final Product Preparation.

You could ask students to turn to their Project Template and do Activity 2. They should write the expressions they learned on page 63. This will help them prepare for their Final Product.

How Am I Doing?

We suggest that you read the statements out loud and clear up any doubts. Then students should mark the things they feel they can now do.

Wrap Up

We suggest that you write the names of animals that students have seen so far on slips of paper. They could play Animal Charades from the Games and Activity section on page xii.

Answers: ► 4 friendly, sad, scared, angry Two, 2. Mom and boy, 3. Playing, 4. Angry, 5. Angry

Achievements

Share questions and answers about the emotions of others. Exemplify expressions said when emotions are shared. Compare actions and emotions of characters. Express emotions about actions and characters as the text is being read to them. Help students to understand why it is important to value and recognize personal emotions.

Suggested Materials colored pencils

Warm Up

Draw emoticons on the board and elicit the feelings they express: *sad, happy, scared, angry.*

Then sing a song in different moods so that students make the gestures and recognize the feelings. Ask students when they feel angry, sad, happy, or scared.

6 Read and circle the correct answer.

First, we recommend explaining that the story is about a duck named Timmy. You could draw students' attention to the pictures and read the text out loud. Then student should circle the correct answers.

Remind them to use the Picture Dictionary.

Write the actions Timmy is doing. You could tell student to write the actions they circled on the lines below.

► Write the actions Timmy is doing.

Students should write the actions they circled in Activity 6.

7 You have read different stories. Draw how they make you feel in the boxes below.

We recommend calling on different volunteers to give a brief summary of the stories. They could say who the characters are and a little bit about what happened in each one. Then students should draw a picture about how each story made them feel in the boxes below.

► Share your answers with a classmate and tell him/her how the stories make you feel.

Students could form pairs and share their drawings. They should share what feelings each drawing shows.

Read and circle the correct answer.

Timmy, a busy duck!



Timmy has many things to do every day. Here he's *walking / swimming* in the farm.

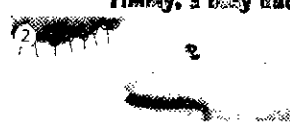

Then he's *running / flying* with his friends.



Now, he's *swimming / walking* in the pond.

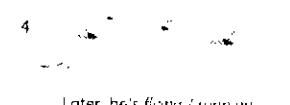

Later, he's *flying / running* very high with his family. Wow, what a busy duck!

Write the actions Timmy is doing.

1. _____
2. _____
3. _____
4. _____

7 You have read different stories. Draw how they make you feel in the boxes below.

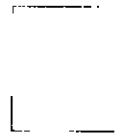

Bianca and the Billy Boys



Pixan Kay



Timmy, a busy duck!

► Share your answers with a classmate and tell him/her how the stories make you feel.

64 Unit 8

Wrap Up

We suggest that you read the following fable out loud. At the end you could ask students about the different feelings of the mouse and the lion.

A lion was sleeping in the forest. A shy little mouse saw him. She was so scared that she ran across the lion's nose. The lion was angry, but the mouse said, "Please let me go and someday I will repay you." The Lion laughed. He didn't think a little mouse could help him, but he let her go. Some days later the lion was caught in a hunter's net and roared very loud. The mouse came and chewed the net so the lion go free. The mouse said, "Now you see that even a mouse can help a lion."

Answers: 5 happy, sad, scared, angry

- 1. Today 2. Pixan Kay, 3. It's Naia, 4. He's, 5. Pixan kay, 6. He's

7. Look, unscramble and complete.

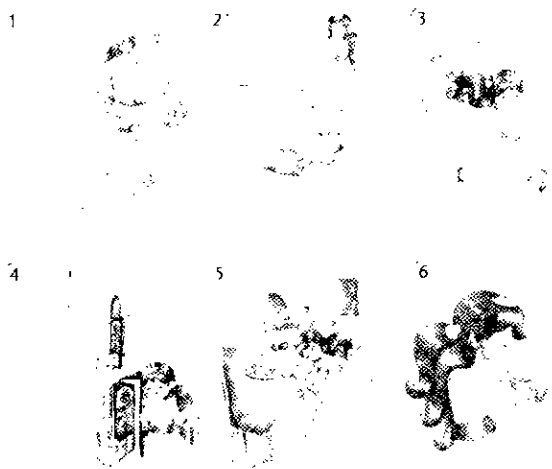

- | | | |
|--------------------|--|--------------------------|
| 1. The princess is | (d n a n c i n g a). | <input type="checkbox"/> |
| 2. The frog is | (a t t a k i n g). | <input type="checkbox"/> |
| 3. The princess is | (r u n n i n g i). | <input type="checkbox"/> |
| 4. She is | (e o p e n i n g) the door. | <input type="checkbox"/> |
| 5. She is | (p u t t i n g) the frog on the table. | <input type="checkbox"/> |
| 6. She is | (k i s s i n g) the frog. | <input type="checkbox"/> |

► Mark (✓) the actions you can do.

► Go to the Project Template on page 97 and do Activity 3.

Then you could read the first sentence. Students should unscramble the word and write what the princess is doing: *dancing*.

► Mark (✓) the actions you can do.

We suggest that you point to the boxes next to the sentences in Activity 8. Students should mark the boxes if they can do the activity the princess is doing.

9 Final Product Preparation.

You could tell students to go to the Project Template and complete Activity 3 by writing the titles of the stories they have read in this unit.

Wrap Up

We suggest that you play Action TPR from the Games and Activities section on page xii. You could use the actions from this unit and previous units.

Answers: 8 1. dancing, 2. talking, 3. running, 4. opening, 5 putting, 6. kissing

Achievements

Complete, with one or more words, sentences referring to actions of their own or the characters'. Complete lists of actions. Compare words in sentences.

Warm Up

You could divide the class into two teams and have students from each team take turns miming an action from their Picture Dictionary. Students could look at actions from past units, too. If the members of their team guess the action in less than a minute, they get a point. The team with the most points wins.

8 Look, unscramble and complete.

We recommend drawing students' attention to the pictures and ask what the story is

T: *What is the story about?* S: *A princess.*

Start with picture one.

T: *What is the princess doing?* S: *She is dancing.*

Continue with the other pictures.

Achievements

Express their creativity to represent actions (sleeping, walking, etc.) contained in a text. Stimulate the appreciation for cultural expressions of other countries. Identify formulaic expression of beginning and end. Revise the use of upper case and lower case letters.

Suggested Materials chalk

Warm Up

You could divide the class into teams. Assign an action to each team (swim, play with a ball, jump, turn round and round, walk, run, fly). We recommend going outside with your students.

Draw a starting line and a finish line, ten meters apart on the ground.

Students should stand in separate single files behind the starting line. Students in each team race to the finish line and back, miming their action as they do so. The first team to finish wins.

10 Final Product Preparation. 8

You could read the instructions out loud and clear up any doubts. It is time for students to prepare their final product. First they should go to the Project Template and choose a story. Then you could ask them to go to Worksheet 8 and write five sentences about the story they chose. Referring back to the Project Template will help them do this. Remind them to illustrate each sentence.

Finally, they should keep this work to prepare the mural in the next class.



For more about sequencing stories go to:
<https://www.education.com/game/sequencing-three-little-pigs/>

Students should go online and write what the story was about on a sheet of paper. We suggest that they keep this to help them prepare their Final Product.

10 Read carefully in order to follow the instructions.

1. Go back to the Project Template on page 97. Choose two stories from the unit to write about them.
2. Now go to Worksheet 8 on page 115. Write five sentences about the story you chose. Remember that you can use the phrases you wrote in the Project Template.
3. Illustrate each sentence. You can use emojis or other drawings to illustrate them.
4. Keep this work to prepare the mural next class.

Go online and write on a sheet of paper what the story was about and how did it make you feel. Keep it in a folder.

66 Unit 8

Wrap Up

Students should form pairs.

Pairs should stand back to back and take turns making a happy, sad, angry or bored face. The student not making the face should try to guess the face his/her partner is making. You could ask some students how they feel:

T: *Are you bored?*

1 Make a hanging mural.

Suggested Materials

- construction paper
- markers or colored pencils
- scissors
- glue

Instructions









1. Get into groups of four and cut out your Worksheets from page 113.
2. Share your work about the story you chose. Take turns reading your sentences out loud and showing how you illustrated them.
3. When you finish, paste your worksheets on the construction paper to make a mural.
4. Write the member of the team below each worksheet.
5. Exhibit your mural.

Group Reflection

- Was it easy to work in your team?
- Was it easy to do your mural?
- Did you like the stories?

Self-evaluation

Color how you feel about your work in this unit.

- | | |
|--|---|
| 1. I can understand stories. |   |
| 2. I learned how to express emotions. |   |
| 3. I can express emotions when I read stories. |   |
| 4. I can write sentences to talk about stories I read. |   |

Unit 3 67

Achievements

Verify the separation of words. Invite your students to value the language as a means to share information which is useful for others. Reflection and self-evaluation.

Suggested Materials construction paper, magazines, paint and paintbrushes, markers or colored pencils, scissors, glue, 1 piece of paper per student

1 Make a hanging mural. 8

Instructions

You could put students into small groups. We suggest that you read and explain the meaning of the instructions to make a hanging mural. You could and provide as much help as necessary, allowing students to make their own decisions.

Group Reflection

You could read and explain the questions to students. They should discuss their answers in groups and reflect on how they made their mural.

Then they could draw a picture of something they learned in the unit. Ask them to share their pictures with the class.

Self-evaluation

Ask students to color the faces according to whether they feel they achieved the objectives or not. Ask them to share their results with a partner before telling them to the class.

Evaluation

Photocopy the Evaluation Instrument: Assessment Rubric on page T67b (1 per student) and complete it for every student.

Product Template

Write a Reading Model

- 1 Write the words you learned on page 61 to express feelings. Then add other words you know.

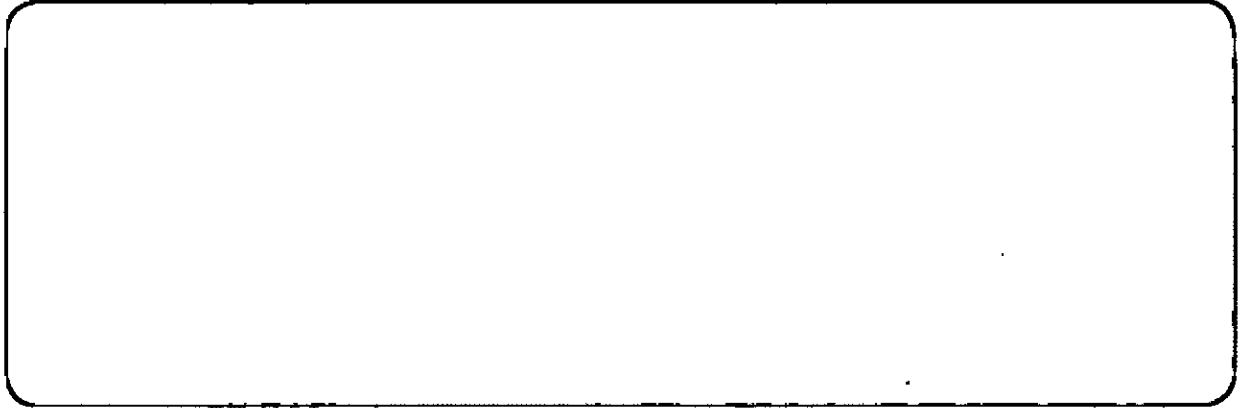

- 2 Write the expressions you learned on page 63.

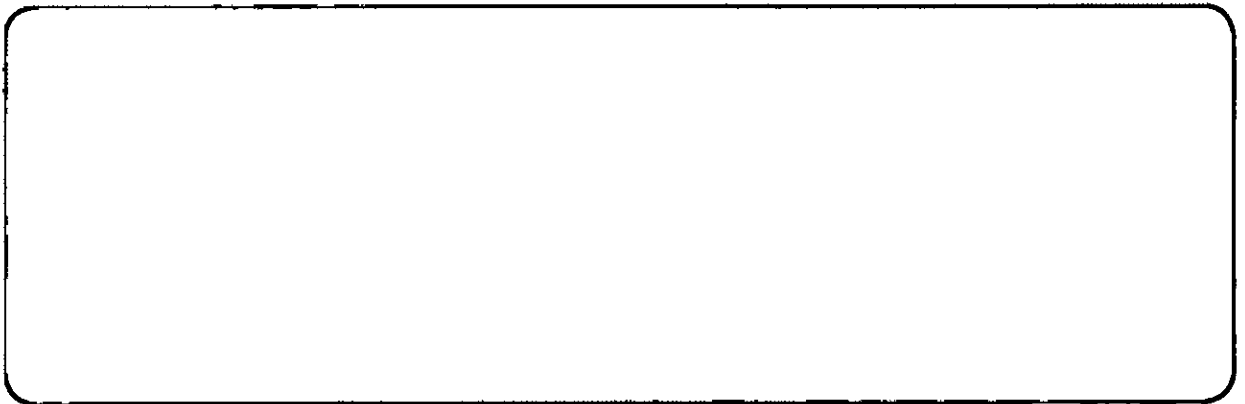

- 3 Write the name of the stories you read in the unit.

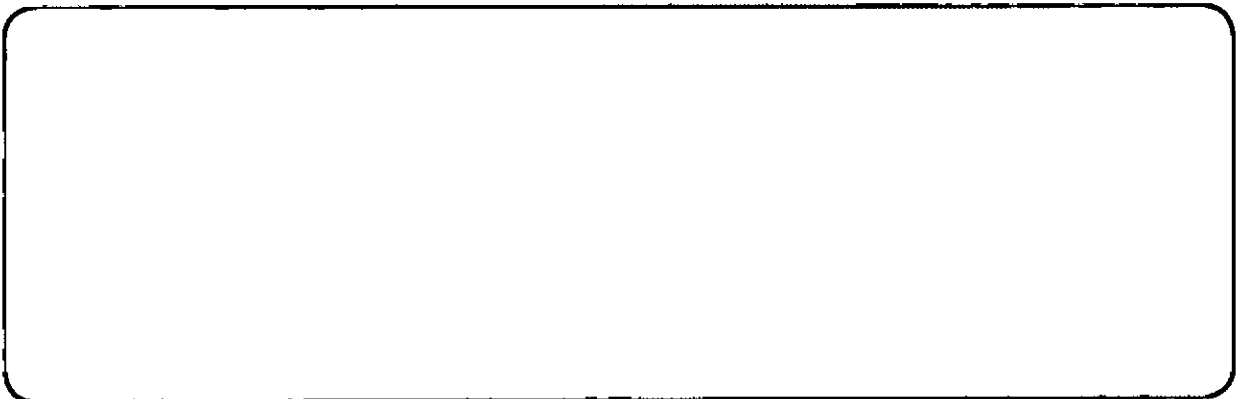

Evaluation Instrument

Unit 8

Assessment Rubric

1 The following assessment rubric can be used to assess students. Write the number of the descriptor that best matches students' performance in the score column. Add up the different numbers and check the overall grading scale below.

Name: _____

Date: _____

	5 Can almost always perform the activities correctly, easily and rapidly	4 Can generally perform the activities correctly and with some ease	3 Can frequently perform the activities correctly despite minor difficulties	2 Can sometimes perform the activities correctly but with some difficulty	1 Can rarely perform the activities correctly and with lots of difficulty	SCORE
Aspect to Be Assessed	Identify parts of a book.					
	Recognize characters in a story.					
	Describe the actions characters are doing.					
	Express emotions.					
	Read stories.					
	Write sentences.					
TOTAL						

GRADING SCALE

- 0 – 12 points: Does not meet standard desired
- 13 – 18 points: Pass though needs improvement
- 19 – 24 points: Pass with a few areas for development
- 25 – 30 points: Pass with very few areas for development

Picture Dictionary

Unit 8

Characters



frog



dolphin



duck



princess

Emojis



bored



sad



happy



angry

Worksheet 8

Title of the story

Unit 9

Let's Make a Chart!

Curricular Objectives

- (A) Exchanges associated with specific purposes.
- (B) Register information of a geography topic with graphic support.

Environment Academic and educational

Final Product: Information on the American continent for a chart.

Big Book: The Americas

Achievements

Explore illustrated maps of the American continent with specific information (language, currency, flag, etc.). Understand information from reading aloud. Participate in writing information.

Suggested Materials world map or globe, colored pencils

Warm Up

Write AMERICAS vertically down the left-hand side of the board. Display a map or globe of the world and point to Mexico. Ask Students to name countries, cities or towns that are part of this continent and that start with one of the letters in the word written on the board.

Unit Overview

1 Look at the chart and locate your country's flag.

Volunteers read the titles of each category in the chart. Next to the flags we find the number of millions of people (inhabitants). Students name the countries they can identify by the flags: *USA, Brazil, Mexico, Argentina, Canada, Guatemala, Panama*. Then ask students to point their country's flag.

► Discuss the questions with your classmates.

Read the questions out loud and explain their meaning to the class. Students discuss the answers in pairs before discussing them with the whole class.

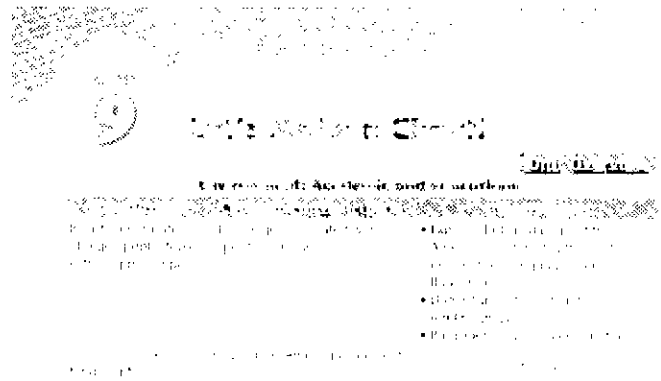

1 Look at the chart and locate your country's flag.

Flag	Population (millions)	Flag	Population (millions)	Flag	Population (millions)
	323		43		3
	204		38		
	123		16		

► Discuss the questions with your classmates.

1. What is the chart about?
2. What countries do you identify? Name them.

► Discuss these questions with a classmate.

Can you locate regions of the American continent on a map? Can you write names of regions and countries of the American continent? Can you locate American countries on a map? Can you write the geographic information on countries of the American continent?

68

How to Use This Chart

Discuss the objectives for the unit with students. Go through the questions one at a time and elicit responses from several students.

Poster

Display Poster 9 for students to play a game of What Is Missing? from page xii. Students should recall the city names and if possible identify the countries before looking at the poster again to check.

Wrap Up

Students could play a game of Draw It! from page xii using flags instead of body parts. They should play with the seven flags on the chart first and then with flags from other nations of the Americas if time.

Answers: 1 1 The United States, 2 Brazil, 3 Mexico, 4 Argentina, 5 Canada, 6 Guatemala, 7 Panama

FORM 3

1 Listen and label the countries you learned about on page 68. 20

Guatemala Canada Mexico Argentina The United States Brazil Panama

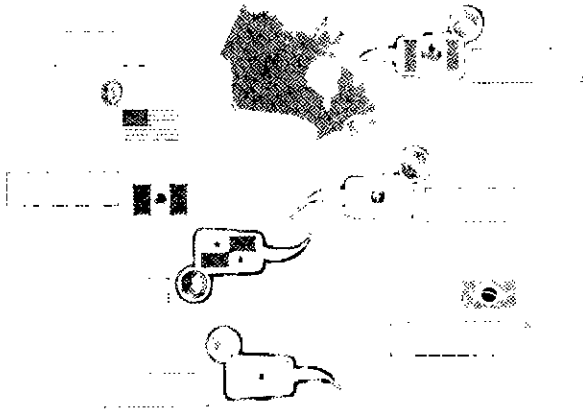

2 Listen, point and repeat. Then work with a classmate. Take turns pointing to the countries and saying their names. 21

3 You have learned different information on pages 68 and 69. Choose two classmates you want to work with as a team. Then go to the Picture Dictionary on page 98 and write the names or draw the flag of 3 countries from the image.

Unit 9 69

Achievements

Identify graphic and textual components.
Locate regions of the American continent on a map.
Point out data or information about the countries.
Identify words when listening. Register in a chart specific data on countries of the American continent.

Suggested Materials colored pencils or crayons (red, orange, yellow, green, blue, pink, gray, brown)

Warm Up

Display each colored pencil or crayon and name the color for students to repeat. Then name different colors and have students point to the corresponding colored pencils.

Display all the colored pencils. Students look at them. Ask students to close their eyes and remove one. Students open their eyes and identify the one missing:

T: Which colored pencil is missing?

1 Listen and label the countries you learned about on page 68. 20

Draw a simple map of the Americas on the board. Students name countries they know.

Students name the colors they can see on the map.

Point to the names of the countries in the box and read them aloud for students to repeat.

Students listen to Track 20 and write the names of the corresponding countries. They can turn to the Picture Dictionary on page 89 to look up the new vocabulary.

► Listen, point and repeat. Then work with a classmate. Take turns pointing to the countries and saying their names. 21

Students listen to Track 21 and point to the corresponding countries, currencies and flags while saying each country's name.

Students need to know that America is divided into three parts: North America, Central America and South America. Students could name other countries that they recognize in each part of the Americas.

2 Final Product Preparation.

Students form groups of three or you could assign them groups. They will work in these groups throughout the unit to prepare for the Final Product. They should choose three countries together and draw their flags and write their names in the Country column of the chart on the Product Template. They should be careful to put each country in the correct region of the Americas.

Wrap Up

Students could play a chain game to end the class, taking turns to repeat the whole of the chain and then add another country each time: I went to the Americas and I visited...

Achievements

Mention names of countries and nationalities to practice pronunciation.

Recognize words similar to those of the mother tongue.

Identify words and phrases, when listening. Review the use of uppercase and lowercase letters.

Warm Up

Invite a student to the front and trace the name of a country on his/her back with your finger. The student says what you wrote. In pairs, students take turns tracing the names of countries on each other's backs.

3 Look at the pictures and read the sentences.

Read the texts out loud as students follow along in their books. Then students can read the texts again quietly to themselves. You may wish to read the texts sentence by sentence for students to repeat after you.

► Discuss with your classmates and teacher.

We suggest reading the questions out loud to the class to make sure everyone understands. Students then form groups of three or four and ask each other the questions. Finally, you could nominate pairs of students to ask and answer a question each for the class.

► Work with a partner. Taking turns introduce yourselves using phrases from exercise 2 as a model

Have your students working in pairs, then using the phrases from the kids above, students choose a different personality and introduce between themselves using the phrases as a model. You can help them with pronunciation if necessary.

4 Listen and sing the rap.

The phrases in different languages appear in the rap that students will hear. Students listen to Track 22 and find the phrases from the rap in their books. Then they listen again and it again and join in rapping.

► Discuss with your classmates and teacher.

This activity can be done as a whole class, with students taking turns to ask and answer, or in groups, in which case students report their answers to the class at the end. Students will recognize the sentences in Spanish and probably the ones in English, but may not know that there are also sentences in German and French.

2 Look at the pictures and read the sentences.



► Discuss with your classmates and teacher.

1. Where are they from?
2. What languages do they mention?
3. Is it important to learn a different language?
4. What other languages can you name?

► Work with a partner. Taking turns introduce yourselves using the phrases from exercise 2 as a model.

4 Listen and sing the rap.

LANGUAGES

At school

How are you?

► Discuss with your classmates and teacher.

1. What languages do you identify?
2. Are they similar to the language you speak?
3. In what countries people speak these languages?

70 Unit 9

Wrap Up

Students could learn how to say "see you later" in French, German and English. Find a recording on line if necessary to help them with the pronunciation.

Answers: 3 ► 1. Mexico, Canada, The United States, Brazil, 2. Spanish, French, English, Portuguese 4 1. German, Spanish, French, English

How are you? See you later! I'm going to bed.

3 Complete the words with the phrases from the box.

Me

na

English

Spanish

ch

4 Compare your answers with a classmate.

6 Complete the chart with the words in the box.

Mexico The United States Brazil Haiti
Cuba Argentina Guatemala Chile



5 Compare your answers with a classmate.

7 Work with your team from page 69. Go to the product template on page 98 and write the language people speak in the countries you have and their region.

Unit 9 71

notice there are no syllables in blue, so these words they have to complete from their own knowledge. Students work alone to complete the words.

► Compare your answers with a classmate.

In pairs, students check each other's answers and correct them if necessary. The incomplete words could be written on the board for volunteers to complete. Students may notice that countries and nationalities start with uppercase letters in English, whereas in Spanish only country names do.

6 Complete the chart with the words in the box.

Students may recall the three regions of America from page 69, where some of the countries in the box featured, too. They have to complete the chart with the countries. If they are not sure, they can wait until they compare their answers with a classmate.

► Compare your answers with a classmate.

Students work with a partner to compare their tables. You may need to point out that Haiti and Cuba (and the other Caribbean Islands) are usually considered part of North America.

7 Final Product Preparation.

Students work in the same groups in which they began their Final Product preparation to complete the chart on the Product Template with more information that they have learned about their countries. They could also add two more countries to their Template and complete the information about them.

Wrap Up

Time to Read Nonfiction: The Americas 31

Display page 39 of the Nonfiction Big Book. Read the title and the name of the author. Point to the pictures and ask students to predict what the topic is.

T: *Is this story about animals? No.*

Is it about countries like Mexico? Yes.

Flip through the pages to confirm students' predictions.

Play Track 31, pausing after the text on each page.

Point to the pictures and encourage students to repeat the names of the countries and languages.

Answers: 5 Countries: Mexico, Canada, Brazil, The United States; Languages: Portuguese, English, Spanish, French 6 North America: Mexico, The United States, Haiti, Cuba; Central America: Guatemala; South America: Brazil, Argentina, Chile



Achievements

Mention names of countries and nationalities to practice your pronunciation.

Write names of regions and countries of the American continent from a model.

Register in a chart specific data on countries of the American continent.

Suggested Materials Nonfiction Big Book, scissors, glue, globe or world map

Warm Up

Students could play an alphabet game in two teams. They take turns naming a country for each consecutive letter A–Z. If the country name is in English, they get two points; if it's in Spanish, they get one point; if they can't think of a country for a letter, they get no points.

5 Complete the words with the phrases from the box.

The syllables in the box at the top have to be used to complete the countries and languages. The syllables are color-coded to make it easier, and students may

Achievements

- Rewrite specific data on countries of the American continent to complete statements.
- Register in a chart specific data on countries of the American continent.
- Raise interest in students about linguistic varieties.

Suggested Materials Nonfiction Big Book, colored pencils, board markers

Warm Up

You could start the class with a board race. Students line up facing the board in two teams. Name a part of the Americas. The first student in each team races to write the name of a country from that region on the board. Other team members can call out ideas and spelling.

8 Look at the graphs and circle T (true) or F (false).

Students will need some help interpreting the graph. Each bar represents a language, and the numbers up the left-hand side are the number of speakers of the language in millions. In pairs, students read the sentences and mark their answers in pencil at first if they prefer before checking their answers with the class.

- **Work with a classmate and correct the false statements in your notebook.**

Students could just correct the figures in the incorrect sentences or they could write a negative sentence followed by the correction if they are able to.

- **Work with a partner. Use the information from Activity 8 to count and color the faces.**

Students work in the same pairs. Copy the key and the number of speakers per language on the board. Show how to cross out a zero in order to represent the number of faces:

T: *How many faces do you need to represent 310 million Spanish speakers? $310 = 31$*

Finally, students color the corresponding number of faces.

Look at the graphs and circle T (true) or F (false).



1. In the Americas, 310 million people speak Portuguese. T / F
2. 300 million people speak English. T / F
3. 180 million people speak Spanish. T / F
4. 12 million people speak French. T / F

- **Work with a classmate and correct the false statements in your notebook.**

- **Work with a partner. Use the information from Activity 8 to count and color the faces.**

1 face = 10 million people. Each face represents 10 million people.

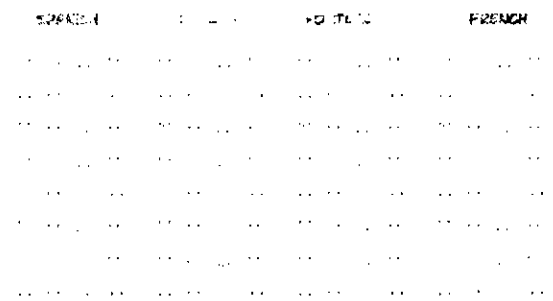

72 Unit 9

Time to read Nonfiction: The Americas

31

Display page 39 of the Nonfiction Big Book. Play Track 31 and turn the pages as the story is told.

Ask a volunteer to come up and point to the map and the graph on page 44.

Ask what they think the colors represent and point out the color key.

Help students to identify a language:

T: *Is Spanish a language?*

Have students identify the different colors on the map:

T: *What language does the color green represent?*

Point to the bar graph at the bottom of the page and explain that it shows how many million people in the Americas speak each language. Ask: *Which language is the most common? (Spanish) Which language is the least common? (French).*

Answers: 8 1. F, 2. T, 3. F, 4. T

► 1. In the Americas, 180 million people speak Portuguese. 3. 310 million people speak Spanish.

► Spanish (31 faces), English (30 faces), Portuguese (18 faces), French (1 face and part of another one)

Form 3

► **Discuss with your classmates and teacher.**

1. What languages do people speak in your community?
2. Do you know someone that speaks more than one language?
3. What languages would you like to speak?

► **Match the countries with the nationalities.**

- | | |
|----------------------|-------------|
| 1. Mexico | American |
| 2. Argentina | Guatemalan |
| 3. Brazil | Mexican |
| 4. The United States | Panamanian |
| 5. Canada | Argentinian |
| 6. Panama | Canadian |
| 7. Guatemala | Brazilian |

► **Compare your answers with a classmate. Take turns saying the name of the country and the nationality.**

 **Write in your notebook the countries you like the most.**

Write in your notebook the countries you like the most. You will use them to prepare your Final Product.

 **Work with your team. Go to the [Word Match](#) on page 98 and write the nationality of the countries you know and two countries from the previous exercise.**

 **Circle your answer. Compare them with a classmate.**

- | | | |
|---|-----|----|
| • I can identify countries and nationalities from the Americas continent. | Yes | No |
| • I can relate countries and nationalities. | Yes | No |
| • I can relate countries with their nationalities and languages. | Yes | No |

Achievements

Identify on a map the country referred to in the information. Register in a chart specific data on countries of the American continent. Mention names of countries and nationalities to practice your pronunciation.

Suggested Materials yarn (brown, black, yellow, red), scissors, glue, strips of paper, colored pencils

Warm Up

Show students how to cut small pieces of yarn and glue them on top of a pencil or colored pencil so the pencil looks as if it has hair. Students then draw two eyes on a strip of paper, cut them out and glue them below the yarn in order to make a "doll."

Ask students to use their dolls to greet their classmates' dolls. They can use Spanish at first, but make sure they use English after.

► **Discuss with your classmates and teacher.**

This activity can be done in groups or as a whole class. If in groups, students need to understand the

questions before discussing them. At the end, you could lead a class discussion.

9 Match the countries with the nationalities.

Nationalities are words that tell us where we are from, and they start with a capital letter. Students should be able to notice the spelling similarities between most of the countries and nationalities in order to do the matching exercise.

► **Compare your answers with a classmate. Take turns saying the name of the country and nationality.**

This could be done as a whole class activity first, with one volunteer saying a country name for another to say the nationality. They may need some help with the pronunciation. When they are confident, students can continue the activity in pairs.

 **Write in your notebook the countries you like the most. You will use them to prepare your Final Product.**

<https://www.esolcourses.com/content/topics/countriesandnationalities/nationalities/5/wordmatch.html>

Students should access the website and choose countries in the Americas for their Final Product. They will use these to continue work on their Product Template in the next activity.

10 Final Product Preparation.

Students work in their Final Product groups to add more information to their Product Templates. They should add the final two countries and complete the nationality column for all their countries.

 **Read and explain the statements.**

Read and explain the statements. Students reflect and circle one answer individually, according to the way they feel in respect to their abilities. Students then compare their answers in pairs or small groups.

Wrap Up

Students could play a spelling game in a circle. One student says a country or nationality, the next says the first letter, the next the second letter, and so on until the word is spelled out. If they have trouble, you could write each nationality on the board.

Answers: 9 1. Mexican, 2. Argentinian, 3. Brazilian, 4. American, 5. Canadian, 6. Panamanian, 7. Guatemalan

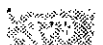

Achievements

Rewrite specific data on countries of the American continent to complete statements.
Register in a chart specific data on countries of the American continent.

Warm Up

Write scrambled names of different languages on the board. Students unscramble them in their notebooks.

11 Look at boys and girls, listen and circle the correct answer. 23

Students describe each child:

T: *Is his hair black? Is her hair short?*

Ask students if they look like him/her:

T: *Is your hair black? Is your hair short?*

Students preview the sentences and possible options under the pictures. Then they listen to Track 23 and circle the correct options. They may need to hear the track more than once.

► Compare your answers with the class.

Volunteers read out the completed information of one person each to report their answers. They could then read or repeat the texts in chorus to practice their pronunciation.

► Work with a classmate. Choose two people each and role-play their introductions in front of the class. Use the phrases in Activity 10 as a model.

In pairs, students choose two of the four children, one each, and memorize their introductions. Pairs then take turns coming to the front of the class and introducing themselves from memory.

12 Final Product Preparation. 9

In their Final Product teams, students transfer the information for five of the countries on their Product Template to Worksheet 9. Currency is not included on the Worksheet.

11 Look at boys and girls, listen and circle the correct answer. 23

1



My name is Lola.
I am Mexican / Brazilian
I speak Spanish / Portuguese

2



My name is Thiago / Pedro
I am Brazilian / Canadian
I speak Portuguese.

3



My name is Robert.
I am / I speak Canadian.
I speak French.

4



My name is Sandy.
I am American.
I am / I speak English.

► Compare your answers with the class.

► Work with a classmate. Choose two people each and role-play their introductions in front of the class. Use the phrases in Activity 10 as a model.

Now you have more information about America. Join with your team from page 69. Go to Worksheet 9 on page 115 and complete it using the information you have in your notebook on page 98.

74 Unit 9

Wrap Up

Time to read Nonfiction: The Americas

Ask a volunteer to come up and find another graph in the story (page 48). Explain that the graph shows the most popular dialects in the Americas. Point to the numbers in millions on the left and read them out loud:

T: *Fifteen million.*

Read the amount of speakers on each bar (e.g., *six million*). Have students name the corresponding dialect and point to the corresponding bar in the graph (*Guarani*).

Answers: 11 1. Mexican, Spanish, 2. Thiago, Brazilian, 3. I am, 4. I speak

1 Make a chart of the Americas. 9

Suggested Materials

- cardboard or bond paper
- glue
- ruler
- scissors

INSTRUCTIONS

1. Cut out the information you have in Worksheet 9 on page 115
2. Make a chart with the information you collected during this lesson.
3. Paste the information on the cardboard or bond paper.
4. Present your chart to your classmates.

Group Reflection

- Was it easy to make a chart?
- Are charts useful?

	Nationality	Language
Honduras	Honduran	Spanish
Cuba	Cuban	Spanish
Ecuador	Ecuadorian	Spanish
Uruguay	Uruguayan	Spanish
Venezuela	Venezuelan	Spanish
Colombia	Colombian	Spanish
Chile	Chilean	Spanish

Self-evaluation

Discuss with the members of your team the following questions. Circle your answers.

- Can you identify different regions of the American continent? Yes. No
- Can you relate countries from America and the region where they are located? Yes. No
- Can you give specific information about countries from the American continent? Yes. No

Achievements

Register in a chart specific data on countries of the American continent.

Reflection and self-evaluation.

Suggested Materials colored pencils, ruler, scissors, reference books, cardboard or bond paper

1 Make a chart of the Americas. 9

Students work by themselves to cut out the information they completed on Worksheet 9 and place it on a sheet of cardboard or bond paper, without gluing it yet. They should research other information about the countries, such as nationality, language, currency, animals, weather, etc. Then have them choose where to write the information. Once you have checked their placement, students glue the information from their worksheet in place to make a chart, and add other information they gathered in writing. They should organize the information about each country in a column or row, and use clear headings. Finally, students take turns presenting their charts. They may just read the words out loud, or if possible, they could form full sentences, in which case some sentence models could be written on the board. Students display their charts in the classroom at the end.

Group Reflection

Divide the class into groups of four. Read and explain the questions. Students talk about the questions in their groups. Ask questions that refer to a personalized situation:

What new countries or languages did you learn in this unit?

What country would you like to visit?

Self-evaluation

Students answer the questions according to whether they feel they accomplished the objectives or not. Ask them what they learned in the unit, what they liked the most and what they didn't like.

Evaluation

Photocopy the Evaluation Instrument: Assessment Questionnaire on page T710 (1 per student) and answer it for every student according to their performance before keeping it in their portfolios.

REGION

COUNTRY

NATIONALITY

LANGUAGE

CURRENCY

UNIT 9

UNIT 9

Canadian Dollar

American

Central America

Portuguese

Assessment Questionnaire

1 The following assessment questionnaire can be used to assess your students.

Name: _____

Date: _____

	Yes	No
Can the student locate regions of the American continent on a map?		
Can the student identify the country referred to in the information?		
Can the student write names of regions and countries of the American continent?		
Can the student mention names of countries and nationalities?		
Can the student complete maps with names of natural spaces and constructions?		
Can the student register in a chart specific data on countries of the American continent?		

- Between 5 and 6 questions were answered with YES – Strong pass
- Between 3 and 4 questions were answered with YES – Pass
- Between 1 and 2 questions were answered with YES – Not satisfactory

Picture Dictionary

Unit 9

Charts



language

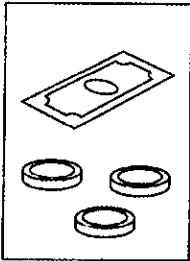

currency

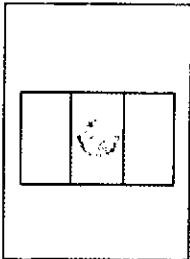

flag



country

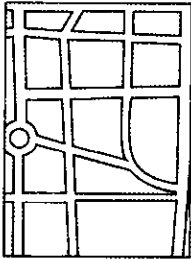

map

Unit 9

Worksheet 9

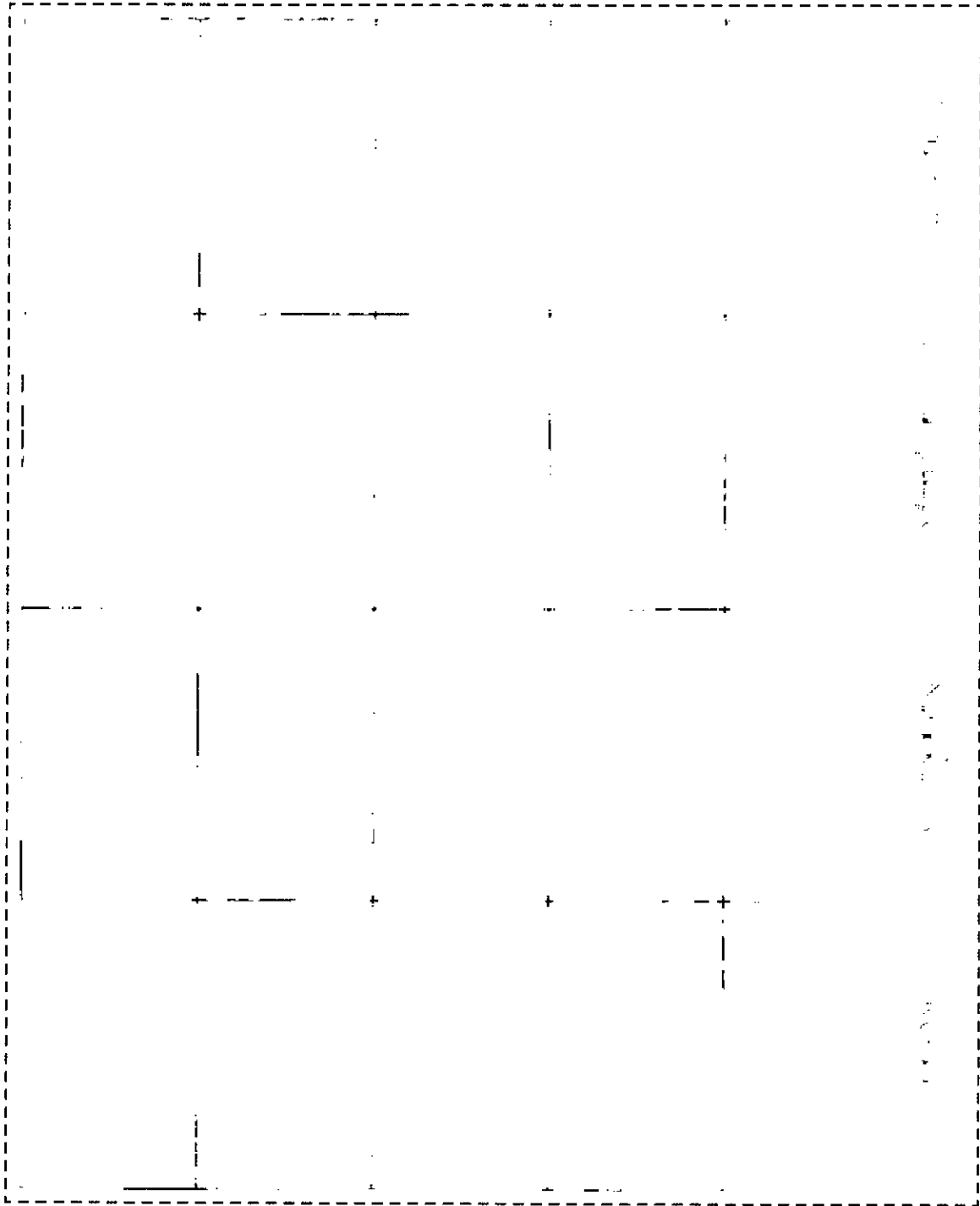

TERM 3

Unit 10

Let's Make a Map!

Curricular Objectives

- (A) Exchanges associated with the environment.
- (B) Understand and register information about locations in the community.

Environment Family and community

Final Product Map with information about community localities.

Big Book Children of the World

Achievements

Explore illustrated diagrams or maps. Exchange information about localities of the community. Write information about the community.

Suggested Materials various maps

Warm Up

To start the unit, students could draw their school on one side of a piece of paper, their house on the other side, and the places they see when they come to school in the middle.

Unit Objectives

1 Look at the map and find and circle the school.

Students should be able to identify the places on the map from their symbols. You may have to write a list of options on the board for them to choose from: bus station, shopping mall, school, subway, hospital, soccer stadium. Students work by themselves to circle the school.

► Answer the questions.

A volunteer could read the three questions out loud before students contemplate their answers in silence.

► Share your answers with a classmate.

Students work in pairs to discuss their answers before reporting them to the class.

How Much Do I Know?

We suggest reading out loud each question before students discuss it in pairs and report their answers to the class.

Unit

10

Let's Make a Map!

Unit Objectives

Environment: Family and community

- Explore the map and identify the places on the map.
- Exchange information about localities of the community.
- Write information about the community.
- Exchange information about localities of the community.
- Write information about the community.

1. Look at the map and find and circle the school.

1 Look at the map, find and circle the school.

► Answer the questions.

1. What is this?
2. What do we use maps for?
3. Can you read maps?

► Share your answers with a classmate.

How Much Do I Know?

Discuss these questions with a classmate.

- Can you distinguish symbols and relate them to places from your community?
- Can you ask and answer questions to offer information about your community?
- Can you complete diagrams or maps with names of natural places and constructions? Can you write information about your community?

Write your answers in your notebook and share with the class.

76 Unit 10

Poster

Display Poster 10 and invite the class to play Choose an Item on page xi.

Wrap Up

To end the class, students could share their previous experiences with maps: Do you use maps? Which ones? What information does a map give you? Distribute the maps for students to discuss in groups what information they can garner from each one.

1 Look and match.

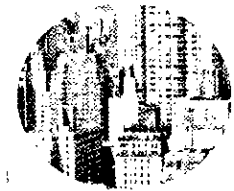

Answer the questions with a classmate.

1. What differences are between a town and a village?
2. What differences are between a town and a city?
3. Where do you live?
4. Do you want to live in any other place? Why?

Achievements

Recognize purpose of diagrams and maps.
 Differentiate graphic and textual components.
 Recognize localities by their names.

Suggested Materials index cards

Preparation: Copy the following letters, one on each of the index cards: C, I, T, Y, T, O, W, N, V, I, L, L, A, G, E.

Warm Up

Distribute the index cards (see Preparation) at random. Spell out the word city and have students stand at the front of the class with the corresponding letters. Do the same with town and village.

Students display the words on the board.

Discussion

1 Look and match.

Students should read the names of the locations in chorus. Help with pronunciation as necessary. Then they decide which map on the right-hand side corresponds to each location. At the end, they could work in pairs to name places on the map that they can recognize.

➤ **Answer the questions with a classmate.**

You could go through the questions first with the class to make sure everyone understands before students discuss them in pairs. Students should take notes on their answers so they can report them to the class.

Point to the words on the board. Have students spell them out with you. Point to each one and ask a few questions to check they understand the difference:

T: *Is a city big? Is a village big?*

Wrap Up

Students form groups according to where they would most like to live: a city, a town or a village. Then groups can discuss why they prefer this place over the others. Finally, groups report their ideas to the class.

Answers: 1 1-c, 2-a, 3-b

Achievements

Look up words in an illustrated bilingual dictionary. Point at names while they are read aloud.

Suggested Materials construction paper (1/4 per group), 1 piece of paper per student, colored pencils, scissors, glue

Warm Up

In the same groups in which they finished the previous class, students draw a village, a town or a city on the construction paper. Name a location and have groups hold up the corresponding picture.

Classify the pictures by location and display them in three different places of the classroom.

Give different instructions and ask students to go to the different locations:

T: *Boys who are seven years old run to the villages.*

2 Listen to the audio, point and repeat. 24

Students should listen to Track 24, point to each of the words as they hear them, and then repeat them. They can look up some of the words in the Picture Dictionary on page 89. They could illustrate the meaning of the other words on the board.

► Classify the words.

Students have to write the words from the previous activity in the correct categories. Many of the words can go in more than one category. At the end, they could draw the chart on the board and take turns adding words to it.

3 Final Product Preparation.

In preparation for the Final Product, students should think about which of the places are in their hometown. They could discuss in pairs or small groups before they commit to writing, and they could also add words for other places in their hometown that don't appear on this page.

Wrap Up

You may want to play Draw it! from page xii using the new words students learned in this lesson.

2 Listen to the audio, point and repeat. 24

mountain river school restaurant museum
subway station hospital bank supermarket
square fire station farm hill police station store

• Classify the words.

city

Town

Village

3 In this unit you will make a map of your hometown. Go to the Picture Dictionary on page 99 and complete Activity 1.

78 Unit 10

Answers: ► City: school, restaurant, museum, subway station, hospital, bank, supermarket, grocery store, store, square, fire station, police station; Town: school, restaurant, museum, hospital, bank, supermarket, grocery store, square, fire station, police station, store; Village: mountain, river, grocery store, farm, hill, store

4 Look at the map and label.

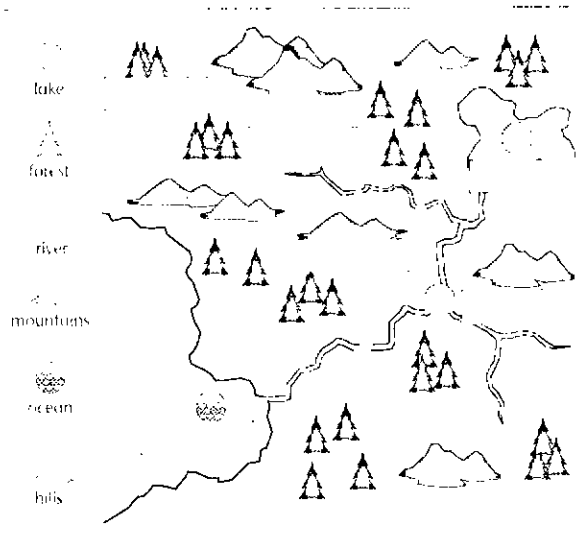

5 Discuss the questions with a classmate.

1. Can you find these places in your hometown?
2. Are they near or far?
3. Which of these places do you like the most?

6 Now, go to the ... on page 99 and do Activity 2.

Unit 10 79

Achievements

Differentiate natural features. Distinguish symbols and relate them with the names they refer to. Classify words according to their meanings. Motivate students to value and appreciate natural features of the place where they live. Complete diagrams or maps with names of natural spaces and constructions. Revise the writing.

Suggested Materials Fiction Big Book, various maps

Warm Up

Students could play a miming game to start the class. Name places that they learned on page 78 and encourage students to act out a related activity for each one.

4 Look at the map and label.

We suggest pointing to the symbols on the left in turn and modeling the pronunciation of the words for students to repeat. Students should then label the places on the map.

Ask students about their favorite natural space:

T: Do you prefer a mountain or a hill? Do you prefer a river or a lake?

5 Discuss the questions with a classmate.

Students should discuss the questions in pairs before reporting their answers to the class. They may wish to give reasons for their preferences for the third question.

6 Final Product Preparation.

Read the sentences and have students answer Yes or No with regard to their hometown.

Wrap Up

To end the class, students could find the physical features that they have learned about on this page on the various maps. They should compare the way the features are represented and how easy they are to recognize.

Time to read Fiction: Children of the World 36

Give the Fiction Big Book to a volunteer and have him/her find the contents on page 1. Ask the student to find the page for the story *Children of the World* (page 39). Hold up the book open to page 39. Read the title and the name of the author. Then draw students' attention to the picture and point to the children and the three maps. Tell students the story is about children and ask them if they can guess what countries they are from by looking at the maps.

Play Track 36 and turn the pages of the book.

Achievements

Distinguish symbols and relate them with the names they refer to.

Suggested Materials 2 pieces of paper, tape, colored pencils

Preparation: Write *yes* on one piece of paper and *no* on the other.

Warm Up

Tape the piece of paper with *yes* (see Preparation) on one wall and the piece with *no* on another.

Ask students what they can find in their city/town:

T: *Is there a square here in (Amecameca)? Is there a market?*

Have students run to the corresponding answer.

7 Match the symbols with the names of the places.

Students should work by themselves to match the symbols with the places. They should match the ones they are sure of first and then see if they can match the remainder.

- ▶ **Work with a classmate and draw the school symbol for your school. Then draw other symbols to indicate the places around your school.**

Students should choose a place for their school on the map and mark it with the appropriate symbol. They can then add symbols for other places according to what there is around their school.

- ▶ **Compare your maps with another pair of classmates and complement it if necessary.**

Pairs form groups of four and compare their maps: Do they include the same symbols? Did they draw them in the same places? Students can modify their maps while they work.

Final Product Preparation

Students should access the website in pairs and watch the video. They should take notes on how to draw a map while they watch to report back to the class.

https://www.youtube.com/watch?Tv=DIUB_5pUF6E

- ▶ **Match the symbols with the names of places.**



- ▶ **Work with a classmate and draw the school symbol for your school. Then draw other symbols to indicate the places around your school.**

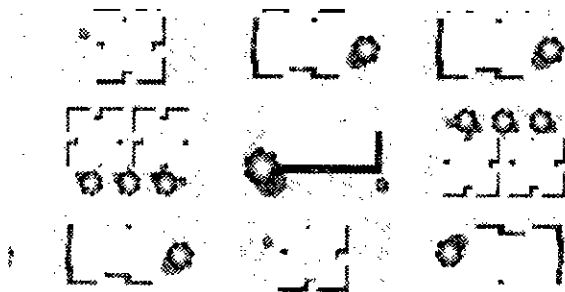

- ▶ **Compare your maps with another pair of classmates and complement it if necessary.**

- ▶  **Watch the video and learn some tips for drawing a map. Discuss with a classmate what you liked about the video.**

80 Unit 10

Wrap Up

Students could collaborate to draw a map of the area around their school on the board. They should include symbols for each place near the school.

2 Listen to the audio and complete. Then listen and point to the pictures. 25

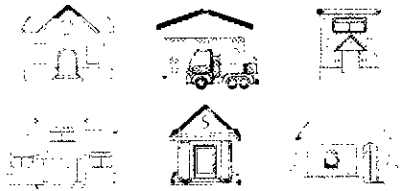

► Listen again and sing along. 25

► Write about your hometown on a separate sheet of paper. Use the sentences in Activity 8 as a model.

► Read your sentences out loud to a classmate.

Think and Discuss

Discuss these questions with a classmate.

- Can you recognize maps?
- Can you distinguish symbols and relate them with the names?

10 Do Worksheet 10 on page 117 using the information from Activity 8. 10

Unit 10 81

Achievements

Identify words and phrases, when listening.
Find similarities and differences between English words and words in their mother tongue.

Suggested Materials Fiction Big Book, paper (1 sheet per student)

Warm Up

To start the class, students take turns drawing a map symbol on the board for others to guess the place that it represents. This activity could be done in teams, with a player from each team drawing a chosen symbol and teams racing to identify it.

8 Listen to the audio and complete. Then listen and point to the pictures. 25

Students identify each of the places:

T: Point to the school.

Then they listen to Track 25 and write the name of the place in each verse.

► Listen again and sing along. 25

Students listen to Track 25 again and point to the places on their map as they sing along.

9 Write about your hometown on a separate sheet of paper. Use the sentences in Activity 8 as a model.

Students write four or five sentences about places in their hometown on a clean sheet of paper. They should keep their sheets in their portfolio.

► Read your sentences out loud to a classmate.

Students work in pairs to practice reading their sentences out loud. Volunteers could read their sentences to the class.

How Am I Doing?

Students discuss the questions in pairs. By this stage, all students should be able to recognize maps and map symbols.

10 Do Worksheet 10 on page 117 using the information from Activity 8. 10

Students work alone to add the six places from the song to their map. They should then compare their locations in pairs.

Wrap Up

Time to read Fiction: Children of the World

Display the Big Book and flip through the pages of the story. Ask students to stand up every time they see a map.

Choose one of the maps and have students describe it to you:

- S: There is a grocery store and a shopping center.
There is a church and a square.

Answers: 8 1. school, 2. restaurant, 3. fire, 4. hospital, 5. police, 6. bank

Achievements

Complete questions to obtain information.
Answer questions to offer information.

Suggested Materials Fiction Big Book, construction paper (1 sheet for the names in the Preparation, and 1 sheet for each student), colored pencils, tape

Preparation: Write the following names of places on each piece of construction paper: school, restaurant, fire station, hospital, police station, bank

Warm Up 25

Display the name of each place (see Preparation) and have students read them. Put the words on different walls of the classroom.

Play Track 25 and have students sing the song *There's a School in My Town*. Students should move or point to the corresponding names as they are mentioned in the song.

11 Final Product Preparation.

Students should work alone to draw an outline of their maps on construction paper. They should include streets and open spaces but not label anything at this stage. You may wish to draw a map of the area on the board if some students have difficulty with accuracy. Students can choose a small area around the school or their house, a whole neighborhood, or even the whole town or city, with only the main streets marked. They may need plenty of time to get their maps right.

12 Listen to the audio and circle the answers.

Students should be able to identify which speech bubbles contain questions: the ones with the question marks at the end. Students listen to Track 26 and circle the answers.

► In pairs, take turns practicing the questions.

Students could listen to the track again and repeat each question and answer. They can then work with a partner to continue asking and answering the questions.

13 Final Product Preparation.

Students will continue work on the map they started drawing in Activity 3 of the Product Template. They should now add details, symbols and place names. They should confer with each other or you if they are unsure.

11 Go to the **Product Template** on page 99 and do Activity 3.

12 Listen to the audio and circle the answers.

Is there a river in your town?

Yes, there is. / No, there isn't.

Is there a mountain?

Yes, there is. / No, there isn't.

Is there a supermarket
in your town?

Yes, there is. / No, there isn't.

Is there a park?

Yes, there is. / No, there isn't.

► In pairs, take turns practicing the questions.

1. Read carefully and follow the instructions.

1. Take out the map you drew on Activity 3 of the **Product Template** on page 99.
2. Use the information you collected on your **Product Template** to help you make a map of your hometown.
3. Now you can include symbols of natural spaces and constructions
4. Write their names.
5. Write the name of your hometown.

82 Unit 10

Wrap Up

Time to read Fiction Children of the World 36

Read the story with the class. Have the class repeat each line of the story after you. Run your finger under the words as you read Play Track 36.

Go back to page 42. Spell out one of the places on the page. Choose a volunteer to point to and say the word. Continue with other pages and other words.

Ask students which of the places in the pictures they have in their town, village or city. Then ask them which ones they have seen in other towns, villages or cities.

Answers: 13 No, there isn't. / Yes, there is. / Yes, there is. / Yes, there is.

Final Product

1 Present a map of your hometown in teams of three. Take turns to talk about your map.



Group Reflection

- Was it easy to draw the map?
- Did you ask for help?
- Is your map useful?

Reflect on the following aspects of your answers.

- I can recognize places in a community.
- I can distinguish symbols and relate them with the names they refer to.
- I can ask and answer questions to offer information.
- I can complete diagrams or maps with names of natural spaces and constructions.
- I can write information about the community.

Self-evaluation

and mark (✓)

	Yes	A little	No
I can recognize places in a community.	<input type="checkbox"/>	<input type="checkbox"/>	<input type="checkbox"/>
I can distinguish symbols and relate them with the names they refer to.	<input type="checkbox"/>	<input type="checkbox"/>	<input type="checkbox"/>
I can ask and answer questions to offer information.	<input type="checkbox"/>	<input type="checkbox"/>	<input type="checkbox"/>
I can complete diagrams or maps with names of natural spaces and constructions.	<input type="checkbox"/>	<input type="checkbox"/>	<input type="checkbox"/>
I can write information about the community.	<input type="checkbox"/>	<input type="checkbox"/>	<input type="checkbox"/>

Achievements

Reflection and self-evaluation.
Write information about the community.

Suggested Materials Fiction Big Book, pieces of chalk, 1 piece of paper per student, construction paper, colored pencils

Warm Up

Students write the name of a town, city or village on a piece of paper. Then they go outside with their papers and stand in separate places. They should draw a cross where they are standing in chalk. Next, students take turns choosing a place that they want to "visit" by looking at their classmates' papers and calculate the number of steps they have to take to get there (Orizaba, 15 steps). Ask them to walk to the place to check.

Final Product

1 Present a map of your hometown in teams of three. Take turns to talk about your map.

Students work in groups of three to present their maps to each other. They can point out places of interest and describe them: There is a hospital. Students should comment on any errors. Volunteers could present their maps to the class at the end if time.

Group Reflection

Students share their opinions in their teams of three. Lead a discussion about how they felt doing their maps, what they found easy and what they found difficult.

Self-evaluation

Students mark the statements according to whether they feel they accomplished the objectives or not. Ask them what they learned in this part of the unit, what they liked the most and what they didn't like.

Evaluation

Photocopy the Evaluation Instrument: Control List T83b (1 per student) and answer it for every student.

Wrap Up

Time to read Fiction: Children of the World 36

Turn to pages 41, 42, 44 and 47 and point out the maps the children drew of the areas where they live. Explain that there are many types of maps: maps of the world, of countries and of towns and cities. There are maps of big areas and of small areas.

Invite students to draw a map of the area where they live. If there is time, invite them to present their maps to the class.

183

Product Template

Continuity of Learning

- 1 Write the names of places there are in your hometown. Use the words you learned on page 78.

Places in my hometown

- 2 Read and write Yes or No.

My Hometown

There are mountains. _____ There is a lake. _____

There are hills. _____ There is an ocean. _____

There is a river. _____ There is a forest. _____

- 3 Write the page numbers in this unit where you can see a map. These examples will help you prepare for the Final Product.

Now, use these maps as models to draw a map of your hometown. You can use construction paper and colored pencils to make the map. Do not include symbols or places yet. Keep your work for the next step.

Form 3



1 The following control list can be used to assess students. Mark the column that best fits students' performance for each descriptor in the list. After completion check the grading scale below.

Name: _____

Date: _____

Aspect to Be Checked	A	B	C
	Can normally perform the activities accurately	Can sometimes perform the activities accurately	Can rarely perform the activities accurately
1 Recognize places in a community.			
2 Recognize the purpose of maps.			
3 Distinguish symbols and relate them with the names they refer to.			
4 Ask and answer questions to offer information.			
5 Complete diagrams or maps, with names of natural spaces and constructions.			
6 Write information about the community.			
7 Differentiate natural features from constructions.			

- More than 4 aspects have a mark in the A column – Strong pass
- More than 4 aspects have a mark in the B column – Pass
- More than 4 aspects have a mark in the C column – Not satisfactory



Constructions

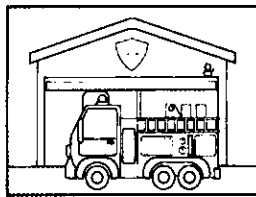

fire station

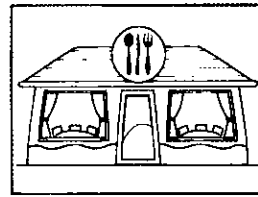

restaurant

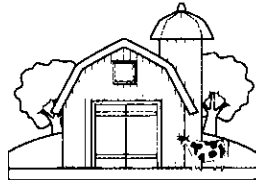

farm

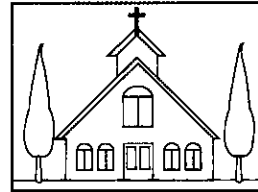

church

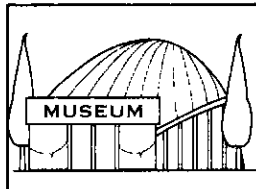

museum

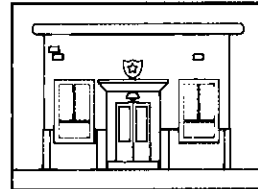

police station

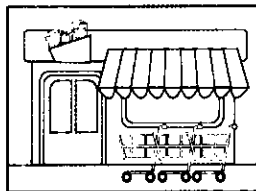

supermarket

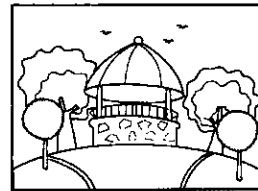

square

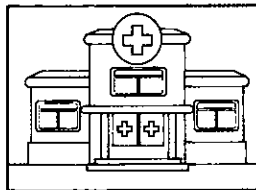

hospital

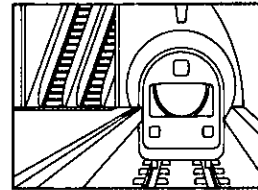

subway

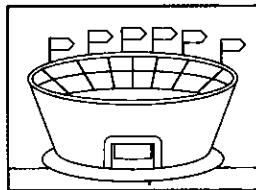

stadium

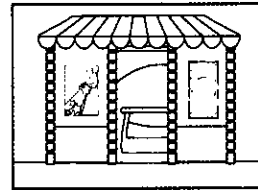

grocery store

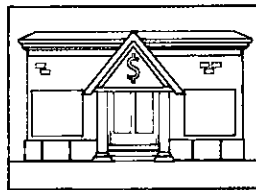

bank

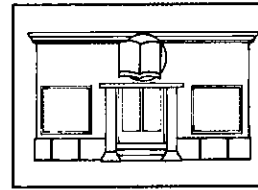

library

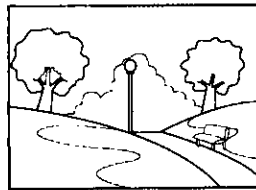

park

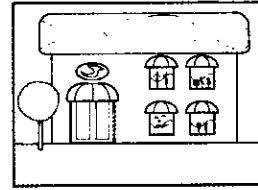

shopping center

Unit 10

Look at Activity 8 on page 81 and draw the places mentioned in the song.

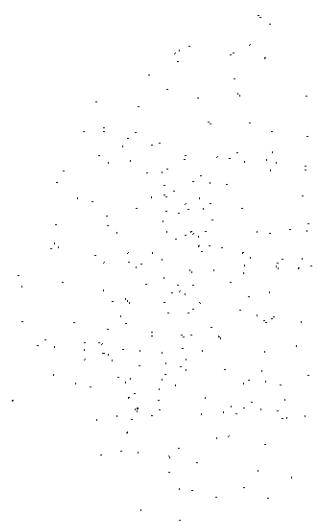

Compare your map with a classmate.



Track 1

MAN: Hello, hello!
My name's John.
WOMAN: Hello, hello!
My name's Rose.
MAN: Goodbye, Rose.
WOMAN: Goodbye, John.
MAN & WOMAN: Have a wonderful day!

Track 2

1. GIRL: Good night.
2. MOTHER: Good morning.
3. HOSTESS: Good evening.
4. TEACHER: Good afternoon.

Track 3

It's a (pencil).
It's a book.
It's a (glue stick).
Look! Look! Look!

Following verse:

2. ... crayon ...
... eraser ...

Track 4

1. BOY: Can you open the window, please?
2. GIRL: Can you pass me my pencil, please?
3. BOY: Can you close the door, please?
4. TEACHER: Can you clean your desk, please?

Track 5

1. BOY: May I go to the bathroom, please?
2. BOY: Can you open the window, please?
3. GIRL: Can you pass me my book, please?
4. GIRL: May I come in, please?

Track 6

BOY: Good morning.
GIRL: Can I borrow your eraser, please?

BOY: May I come in, please?
GIRL: Can you pass me my pencil, please?

Track 7

Hickory Dickory Dock

Hickory dickory dock.
The mouse ran up the clock.
(The clock struck one,
The mouse ran down.)
Hickory dickory dock.

Following verses:

2. The clock struck two,
The mouse said, "Boo!"
3. The clock struck three,
The mouse said, "Whee!"
4. The clock struck four,
The mouse said, "No more!"

Track 8

Grandma's Spectacles

These are Grandma's spectacles,
This is Grandma's hat.
This is the way she folds her hands,
And lays them in her lap.

Track 9

Three Little Monkeys Jumping on the Bed

(Three little monkeys) jumping on the bed.
One fell off and bumped his head.
Mommy called the doctor and the doctor said,
"No more monkeys jumping on the bed!"
Following verses:
Two little monkeys...
One little monkey jumping on the bed.
He fell off and bumped his head...

Track 10

How Many Apples?

How many apples,
Do you see?
Can you count them?
One, two, three.
How many green ones?
How many red?
Now eat an apple,
And go to bed.

Track 11

1. Recycle arrow
2. toilets information text
people silhouette arrow

Track 12

1. Exit to the right.
2. Don't take pictures.
3. Be careful with the wet paint.

Track 13

What can you see?

Look in the sea.
What can you see?
I see (a crab),
And the (crab) sees me.
Following verses:
...a fish,...
...an octopus,...
...a starfish,...

Track 14

I Look at You

I look at you and I can see,
You are you,
And I am me.
Long hair or short hair, curly
or straight,
Just look at us, we both
look great!
Eyes that are brown or green
or blue.
Yes, I am special, and so
are you!



Track 15

1. shoe, blue
2. moon, spoon
3. sun, fun
4. three, bee
5. town, clown
6. cat, hat

Track 16

1.
 WOMAN: What is your name?
 RICKY: Ricky.
 WOMAN: How do you spell your name?
 RICKY: R-I-C-K-Y
 WOMAN: How old are you?
 RICKY: I'm eight.
 WOMAN: When is your birthday?
 RICKY: It's on August 1st.

2.
 WOMAN: What is your name?
 GIRL: Gloria.
 WOMAN: How do you spell your name?
 GLORIA: G-L-O-R-I-A
 WOMAN: When is your birthday, Gloria?
 GLORIA: On March 21st.
 WOMAN: How old are you?
 GIRL: I'm seven.

Track 17

The Months of the Year

January, February,
 March and April,
 May and June and July.
 August, September,
 October, November,
 December.
 I can say the months of
 the year!

Track 18

1. WOMAN: What do you do in your free time, Ricky?
 RICKY: I like to watch TV and play video games.

2. WOMAN: What do you do in your free time, Gloria?
 GLORIA: I like to knit and ride my bike.

Track 19

1) GIRL: What is your name?
 BOY: My name is Tom.
 2) GIRL 1: How old are you?
 GIRL 2: I am seven years old.
 3) Teacher: Alan, when is your birthday?
 BOY: My birthday is on February 7th.
 4) GIRL 3: What do you do in your free time?
 BOY 2: I like to play video games.

Track 20

BOY: This is a map of the Americas. Look at the flags! That is Canada. It's in red. They use the Canadian dollar. That's the United States. It's in pink. They use the dollar. That's Mexico. It's in green. We use pesos. That's Brazil. It's in orange. They use the real. That's Panama. It's in purple. They use the Balboa. That's Argentina. It's in yellow. They use Argentinian pesos. And that's Guatemala. It's in brown. They use the Quetzal.

Track 21

1. Brazil
2. The United States
3. Canada
4. Guatemala
5. Mexico
6. Argentina
7. Panama

Track 22

Languages

Languages are nice, yeah!
 Languages are cool.
 Some you learn at home, and some you learn at school.
 In Spanish, How are you? is ¿Cómo está usted?
 Me voy a dormir, means I'm going to bed.
 In German, Auf wiedersehen, means See you later!
 Nos vemos, Au revoir, I'm a super translator!
 What do you speak at home with your family?
 Spanish, or Nahuatl, or Maya, maybe?

Track 23

1) GIRL 1: My name is Lola.
 I am Mexican.
 I speak Spanish.
 2) BOY 1: My name is Thiago.
 I am Brazilian.
 I speak Portuguese.
 3) BOY 2: My name is Robert.
 I am Canadian.
 I speak French.
 4) GIRL 2: My name is Sandy.
 I am American.
 I speak English.

Track 24

mountain
 supermarket
 river
 store
 school
 square
 restaurant
 fire station
 museum
 farm
 subway station

hill
hospital
police station
bank

Track 25

There's a School in My Town

There's a (school) in my town,
in my town.
There's a (school) in my town,
in my town.
Look up and look down.
Find the (school) in my town,
in my town.
Following verses:
2. restaurant
3. fire station
4. hospital
5. police station
6. bank

Track 26

BOY: Is there a river in your town?
GIRL: No, there isn't.
BOY: Is there a mountain?
GIRL: Yes, there is.
BOY: Is there a supermarket in your town?
GIRL: Yes, there is.
BOY: Is there a park?
GIRL: Yes, there is.

Nonfiction Big Book

Track 27

Being Polite

KID 1: "Hi!"
KID 2: "Hello!"
NARRATOR: Greet people when you meet them.
WOMAN: Good morning!
MAN: Good afternoon!
WOMAN: Good evening!
NARRATOR: We use different expressions to greet people, depending on the time of the day.

NARRATOR: When you need something, ask for it and say "please."

GIRL 1: Can I borrow your eraser, please?

GIRL 2: Sure!

BOY: Can you check my homework, please?

WOMAN: Of course!

NARRATOR: Always be polite, with children and also adults.

NARRATOR: When you need someone to do you a favor, ask politely.

BOY: Can you give me my pen, please?

GIRL: Sure!

KID 1: Thank you!

KID 2: You're welcome!

NARRATOR: Remember to say "Thank you" and "You're welcome."

GIRL: May I go to the bathroom, please?

NARRATOR: Ask for permission to do things.

NARRATOR: And when it's time to leave, say "Good-bye!"

WOMAN AND KID: Good-bye!

BOY 5: Bye!

PARENTS: Good night!

NARRATOR: Now you know how to be polite!

Track 28

A Different Way to Grow Plants

Can plants grow without soil?
What is hydroponics?
Hydroponics is a method of growing plants in water without soil.
Is hydroponics a new method?
No, it isn't. This method was used by Aztecs in Mexico and by other civilizations many, many years ago.
What do plants need to grow?

They need water. "Hydro" means water.

Plants need light indoors...
... and sunlight outdoors.

Plants need nutrients.

Hydroponic plants do not get the nutrients from the soil, so nutrients have to be added.

Plants also need air.

What vegetables can be grown with this method?

Many vegetables can grow in a hydroponic garden.

These are some examples.

spinach

lettuce

cucumber

tomato

But you could grow many more.

There are different hydroponic systems for growing plants.

Here are the instructions for an easy one.

Prepare your seeds.

1. Choose your seeds.

2. Wrap seeds in a wet paper towel.

3. Put bag in a warm dark place.

Let seeds germinate.

4. Cut holes in the paper towel for stems to grow.

5. Watch the stems grow.

Transfer to a permanent container.

6. Fill with water.

7. Submerge only the roots.

Take care of your plant.

8. Change water every two or three days.

9. Add nutrients once a week.

10. Enjoy your plant.

Track 29

All about Fruits and Vegetables

Fruits and vegetables are plants.

What are fruits?
 Fruits have seeds.
 What are vegetables?
 Vegetables are the edible part of plants.
 They can be leaves, stems, roots or flowers.
 What color are fruits and vegetables?
 Fruits and vegetables come in all colors: orange, green, red, yellow, blue, white, pink and more.
 What do they look like?
 Some are round, like lemons.
 Some are oval, like grapes.
 Others are like flowers, like broccoli. Others are like triangles, like strawberries.
 Others are long, like cucumbers. And others have another shape, like pears.
 Are they big or small?
 Some are big, like watermelons.
 Some are small, like peas.
 What do they taste like?
 Some are sweet, like carrots and apples.
 Some are sour, like lemons or grapefruits.
 What do they feel like?
 Some are hard, like potatoes.
 Some are soft, like bananas.
 Others are bumpy, like melons.
 And others feel smooth, like peaches.
 But all fruits and vegetables are good for you.
 They help you to grow, give you vitamins and keep you healthy.

Track 30
Collections

Collecting is a popular hobby.
 People collect different things.
 Collecting is a popular hobby.

People collect many different things.
 Hi! My name is Carla. I'm interviewing people about the things they collect.
 First, I asked my little sister. Maria, what do you collect?
 I collect teddy bears. I have 16 of them. I love teddy bears!
 My uncle was visiting so I asked him. Uncle Daniel, what do you collect?
 I collect coins: old coins, new coins, coins from Mexico and coins from around the world.
 Here is my grandfather. Grandpa, what do you collect?
 I have a collection of vinyls. Some of them are very old. I have had them for many years.
 I already know what my mother collects but I'll ask. Mom, what do you collect?
 I have vases from different regions in Mexico. They are very beautiful.
 Now I'll ask my teacher. Miss Patricia, do you collect anything?
 Yes, I do. I collect bottles. Some have unusual shapes and colors.
 Finally, I'll ask my best friend. Melanie, what do you collect?
 I have a collection of seashells. Some are small and some are big. My grandmother gave me most of them.
 Here are the results of my investigation.
 Collecting things sounds like fun. I want to start a collection, too. What about you?

Track 31
The Americas

There are 35 countries in the Americas.

The continent is divided into three sub-continents.
 North America: You can see Canada, the United States and Mexico here.
 Central America has 20 countries.
 Some of them are Guatemala, Belize, Cuba and Haiti.
 South America has 12 countries.
 Some of them are Argentina, Brazil, Chile, Colombia, Uruguay and Peru.
 The most important languages are Spanish, English, Portuguese and French.
 People speak Spanish in Mexico and most of Central and South America.
 People speak English in the United States and Canada.
 They speak Portuguese in Brazil.
 And they speak French in parts of Canada.
 In the Americas, people also speak some dialects, like Quechua, Guarani, Maya and Nahuatl.

Fiction Big Book

Track 32
Do the Elephant Walk

An elephant walks like this and that.
 He's terribly tall and terribly fat.
 He has no fingers and no toes.
 But goodness gracious, what a nose!
 My friends, they walk like that and this.
 I don't know why on earth that is.
 They walk backwards and to the right.

Then forwards to the other side.
They wiggle about.
Then jump and shout.
Can you walk like my best
friends do?
And can you do what I
can, too?

Track 33

Taking a Walk

GIRL: Look, Mom! A
bicycle lane.
MOM: You're right! Look! Let's
throw away our bottles here.
NARRATOR: It's fun to walk down
the street and see many things.
Let's find the signs.
MOM: Let's ask where the
exhibition is.
GIRL: Can I have one of those?
NARRATOR: We can find out
about the things to see at the
information desk and from
the signs.
GIRL: Wow! There are so many
signs. It says we can't eat
in here.
MOM: And we can't take photos.
NARRATOR: Signs help us to know
what we can and can't do in
a museum.
GIRL: Let's cross here.
MOM: No. Let's walk to the
pedestrian crossing.
NARRATOR: When you are on the
street, always look around you.
Signs are made to help us.
GIRL: Mom, can we go to
the park?
MOM: Yes. Let's follow the sign.
NARRATOR: Some signs show us
where we are and how to get to
where we want to go.
GIRL: Look, Mom. We can't step
on the grass. And we can't pick
the flowers.

MOM: That boy didn't see the
sign. He needs a helmet.

NARRATOR: Signs help to keep
the park clean and beautiful
for everyone to enjoy.

MOM: Let's sit here and watch
the ducks swimming in the
pond.

GIRL: I guess the ducks didn't
see the sign either.

NARRATOR: We have to look
at the signs in the park and
everywhere we go.

MOM: I love libraries!
Don't you?

GIRL: Shhh, Mom! We can't talk
in here. Please turn off your
cell phone.

NARRATOR: We need silence in
the library. People come here to
study and read.

GIRL: Look Mom! That's the
exit. Let's go.

MOM: But first, I need to go to
the bathroom.

NARRATOR: The signs on the
doors tell us which bathroom
to enter. Exit signs show the
way out.

GIRL: Look! There are signs on
the stores, too.

MOM: Yes. That's where we buy
our bread.

NARRATOR: Stores have signs
that show us what we can
buy there.

GIRL: Let's go back home, Mom.
I want to make some signs.

MOM: Be careful! Red means we
have to stop and wait.

NARRATOR: Signs and traffic
lights are important. They keep
us safe.

MOM: Now I know what I can
do in your bedroom.

GIRL: Yes! Look, the ladies'

bathroom is right there.

NARRATOR: Now the bedroom is
full of signs. Do you want to
make signs for your bedroom?

Track 34

The Noisy, Busy Farm

The farm is noisy and busy in
every way.
The farmer drives his tractor
and brings the hay.
Mother duck says quack, quack,
quack.
As she swims with a baby on
her back.
The pigs say oink, oink all
day long.
And play in the mud when the
farmer is gone.
They love to eat and aren't
very neat.
But when they're clean, they're
kind of sweet.
In the field there's a mother cow
with her baby.
She moos and eats, but she's a
little lazy.
And when the moon is
shining bright, they go to the
barn to stay all night.
The baby chicks are yellow like
the sun.
They sing peep, peep and have
some fun.
They run, but they don't know
how to fly.
Maybe because they never try.
The sheep have wool that's curly
and thick.
It keeps them warm so they
don't get sick.
They say baa, baa, baa and I
can hear.
But they're shy and won't let
me near.
The farmer says, "It's getting

late. It's time for bed.
I want to rest and clear
my head.
All day you quack, oink, moo,
baa, oink, quack and peep.
Now please be quiet, and let
me sleep!"

Track 35

The Frog Prince

PRINCESS: I'm a glorious princess.
I have beautiful eyes.
I can sing. I can dance!
Oh, no! I can't swim!
FROG: I can swim and I can
get the ball for you. On one
condition: Let me be your
best friend.
PRINCESS: Okay, whatever.
FROG: Here's your ball...
Hey, wait!
I can't run that fast!
Wait for me! I'm your
best friend!
FROG: Open the door!
You made a promise!
PRINCESS: Okay, whatever.
FROG: Let me eat at your table.
PRINCESS: Okay, whatever.
FROG: I'm tired. Take me to
your bed.
PRINCESS: Okay, whatever.
FROG: Now give me a kiss!
PRINCESS: NO!
FROG: I said, give me a kiss!
PRINCESS: I said, NO!
FROG: You made a promise!
PRINCESS: Okay, whatever.
PRINCESS: Oh, your hair is long,
your eyes are brown; you are
my hero! Marry me!
PRINCE: Okay, whatever.

Track 36

Children of the World

Hi! My name is Miriam.
I am from Mexico.
This is a plan of where I live.
I live in an apartment in
that building.
There is a shopping mall
nearby, a church and a
small square.
There are many grocery stores
and a video store, too.
Hello! My name is Charlotte.
And this is my pet kangaroo.
His name is Joe.
We are from Australia.
I live on a ranch with sheep.
There isn't a school near.
There are only a few farms or
ranches.
But I live near the ocean.
So I can go to the beach
every weekend.
My name is Raj.
I am from India.
I live in a small village.
There is a temple, a pond and
many sitting spaces with trees.
And there are many fields
where my family works.
My school is next to the village.
So my sister and I walk there,
or sometimes we ride our bikes.

Look and match.

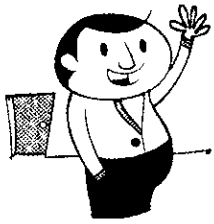

Hello!



Hi

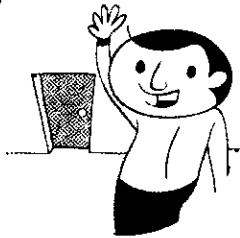

Goodbye!

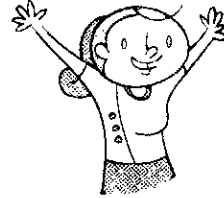

Bye

Look and number the pictures.



1. Can you open the window, please?
2. Can you pass me my pencil, please?
3. May I go to the bathroom, please?
4. Can I borrow a pencil sharpener, please?

Read and circle.

two = blue

three = red



bee



Boo!



shoe



glue

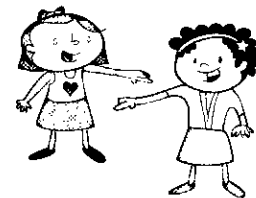

we



tree



Look and write the titles. Then circle the question.

Instructions Materials

What does a magnet attract?

magnet
2 sheets of paper
objects

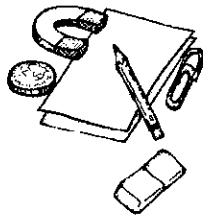

1. Write "attracts" on one paper. Write "doesn't attract" on the other paper.
2. Test the objects with a magnet.
3. Put the objects on the correct paper.

Look and number the steps.

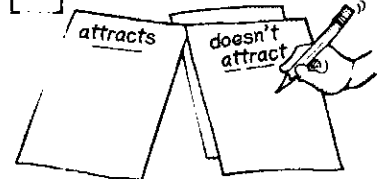
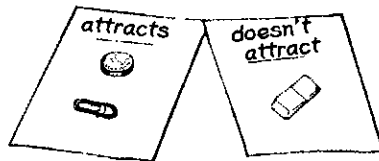
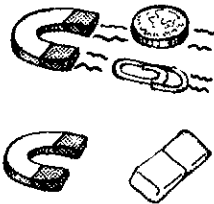

Complete the instructions with the words in the box.

Don't Be Exit Recycle

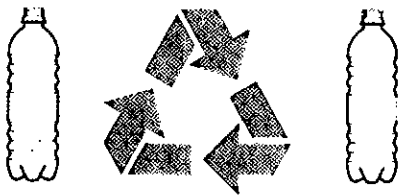

_____ plastic bottles.



_____ use your bike.



_____ careful with the dog.

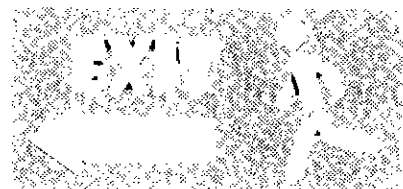

_____ to the left.



Name: _____

Look and write the words.

s-p-o-o-n

s-h-o-e

g-l-u-e

s-u-n

c-a-t

t-h-r-e-e

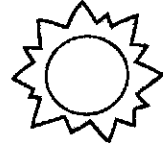

Listen and complete.  18

you me

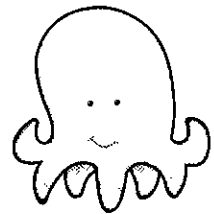

What Can You See?

Look in the sea.

What can you see?

I see a crab,

And the crab sees _____.

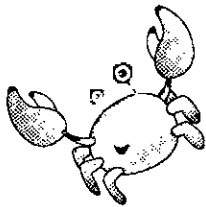

Match.

1. cucumber
2. guava
3. watermelon
4. broccoli
5. strawberry
6. banana

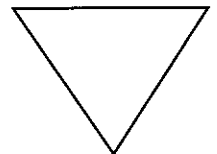
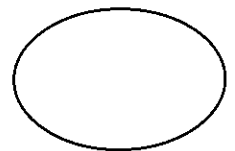
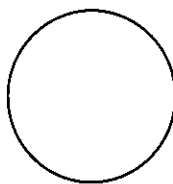

Unscramble the question. Then write the answer.

color / is / What / banana / a / ? _____



Name: _____

Assessment 4

Number the months.

February January August October
 September December March
 June November July April May

Match.

- | | |
|---------|------------------------------|
| 1. What | old are you? |
| 2. How | do you do in your free time? |
| 3. When | is your name? |
| 4. What | is your birthday? |

Circle the characters of the story *The Frog Prince*.



- | | |
|----------|----------|
| cat | witch |
| elephant | princess |
| prince | frog |

Draw the beginning and the end of the story.

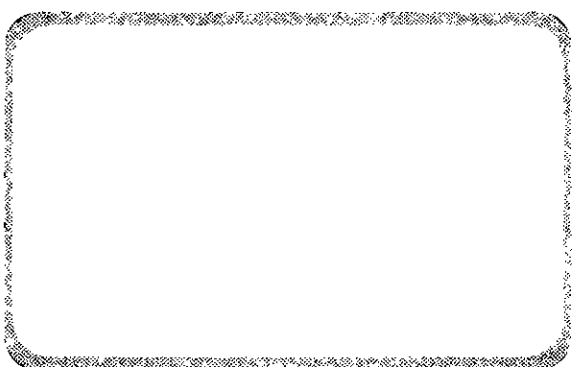
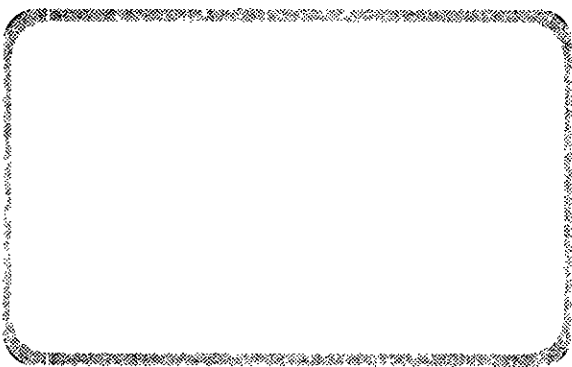

1. Complete the chart using the words in the box. Write the categories on the top line.

Spanish Portuguese English Canada The United States Mexico
 Mexican American Canadian Brazil French Brazilian

2. Complete.

1. I'm from _____. 2. I speak _____.

3. Draw.

river

forest

lake

mountain

4. Circle the answer.

1. Is there a supermarket?
Yes, there is. / No, there isn't.
2. Is there a hospital?
Yes, there is. / No, there isn't.
3. Is there a bank?
Yes, there is. / No, there isn't.

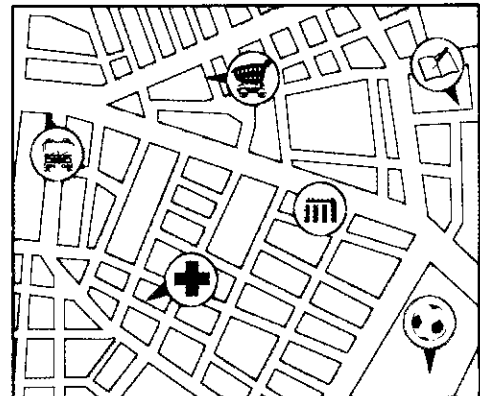

Name: _____

Look at the pictures. Look at the letters. Write the words.

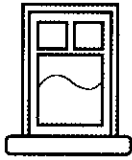

1. _____
(d o w n w i)

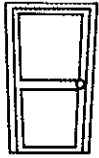

2. _____
(o o d r)



3. _____
(t n p l a)



4. _____
(p t o)



5. _____
(g w o r)

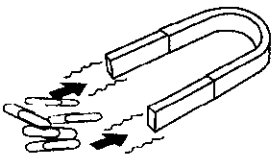

6. _____
(t t a r c t a)



7. _____
(e k i b)



8. _____
(n o t i h i p r o b i)

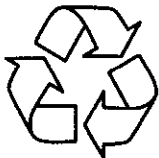

9. _____
(l e r e c y c)



10. _____
(p m r a)



Name: _____

Look and read. Write *yes* or *no*.

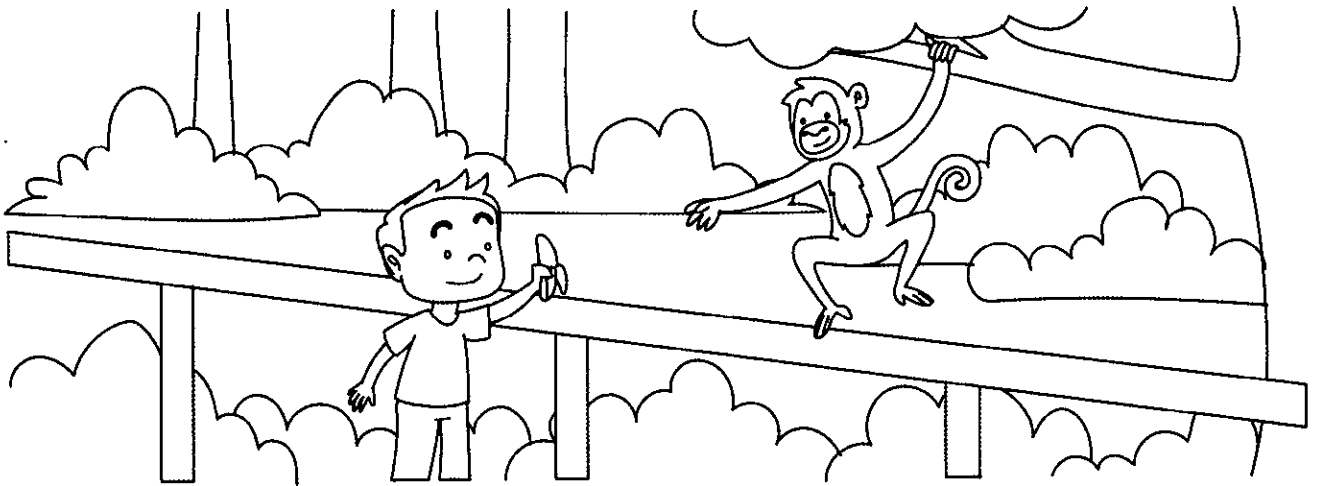
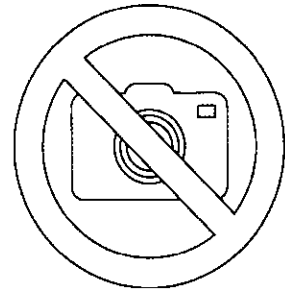
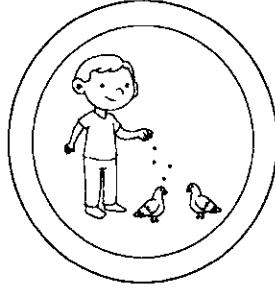

1. They are at school. _____
2. They are at the zoo. _____
3. There is one boy. _____
4. There are two monkeys. _____
5. The boy feeds the monkey. _____
6. There is one banana. _____
7. There is one sign. _____
8. Don't feed the animals. _____
9. Don't use a bike. _____
10. Take photos. _____



Name: _____

Look at the pictures. Look at the letters. Write the words.



1. _____
(st u o c o p)



2. _____
(o r t s h)

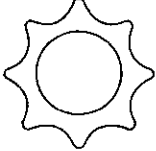

3. _____
(y d a)



4. _____
(t h g i n)



5. _____
(e s l e a v)

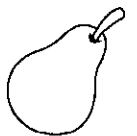

6. _____
(i u t f r)



7. _____
(e a d r)



8. _____
(m i w s)



9. _____
(y a p l o e i d s e g a m)



10. _____
(i d r e a e k i b)



Look and read. Write *yes* or *no*.

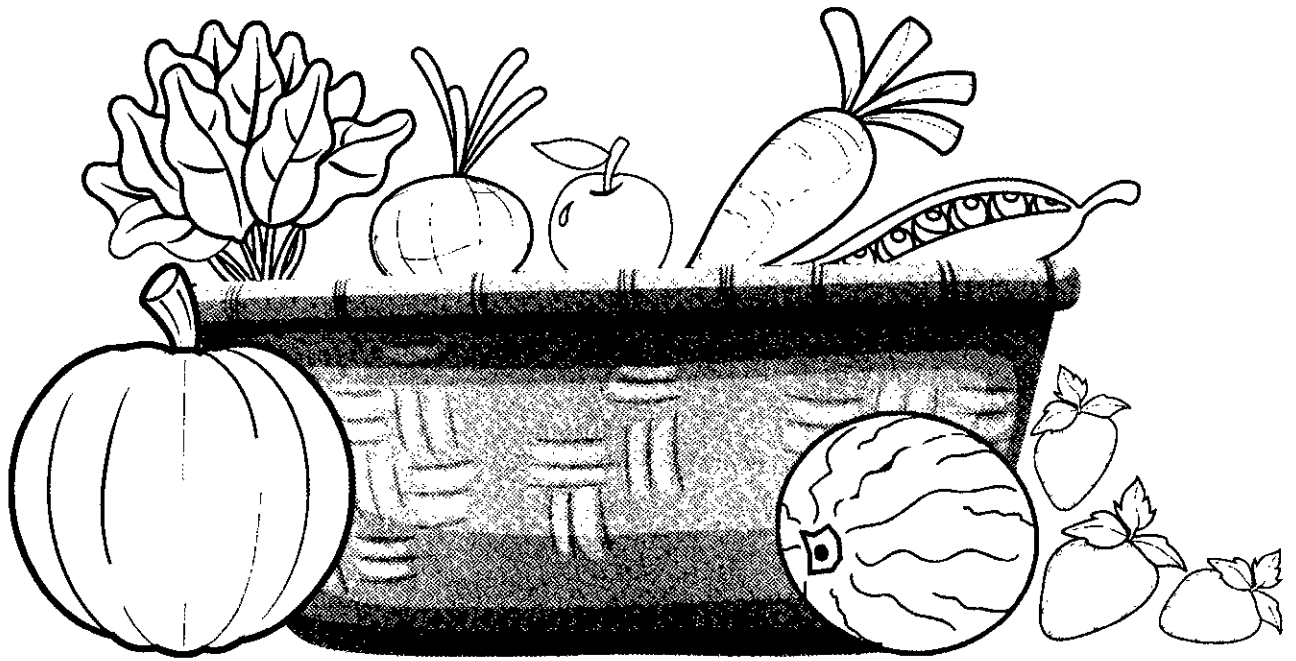

Domain 2

1. Some fruits have seeds. _____
2. Flowers are vegetables. _____
3. Papayas are big. _____
4. Peas are small. _____
5. Broccoli is green. _____
6. Bananas are fruit. _____
7. There is a carrot. _____
8. There isn't spinach. _____
9. There is a melon. _____
10. There are three strawberries. _____

Name: _____

Look at the pictures. Look at the letters. Write the words.



1. _____
(y l f)



2. _____
(c h t i w)



3. _____
(c e s s p r i n)



4. _____
(p h i n d o l)



5. _____
(g u a g e l a n)



6. _____
(g a f l)



7. _____
(t r y c o u n)

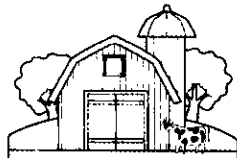

8. _____
(a r m f)

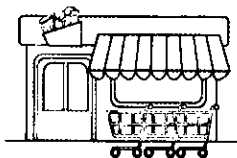

9. _____
(m a r s u p k e t e r)

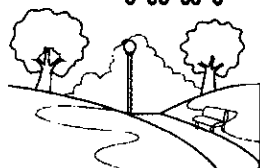

10. _____
(k p a r)



Look and read. Write *yes* or *no*.

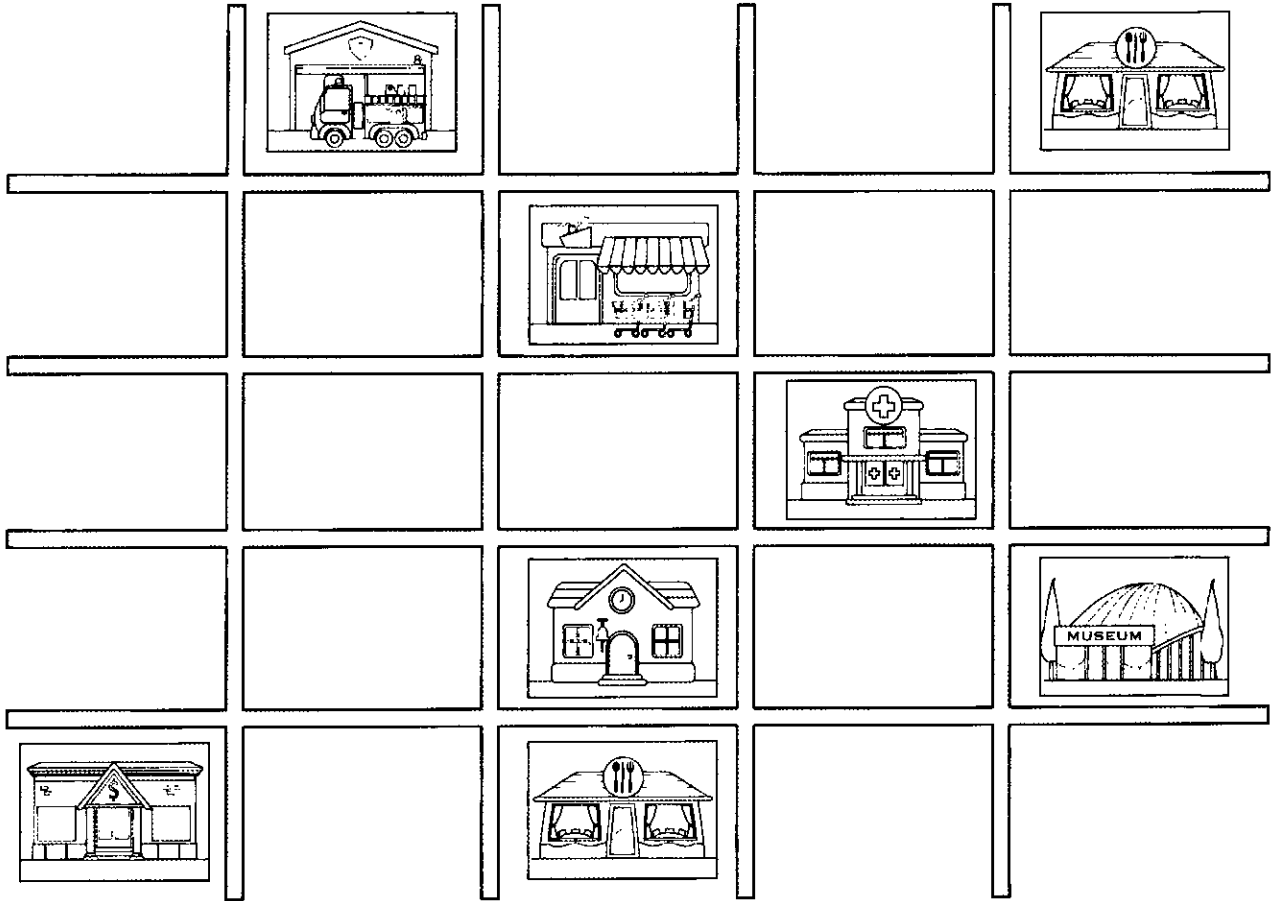

1. This is a map of The Americas.
2. This is a map of a village.
3. This is a map of a town.
4. There is a park.
5. There isn't a supermarket.
6. There is a museum.
7. There are two restaurants.
8. There is a fire station.
9. I can see natural spaces on the map.
10. I can see constructions on the map.





DIPLOMA

completed  level 2
Congratulations!

Teacher:



Student:

For Students (Guided Reading)

1. Bridwell, Norman (1975). *Clifford's Good Deeds*. Scholastic.
2. Carle, Eric (1994). *The Very Hungry Caterpillar*. Scholastic.
3. Castrillón, Melissa & Laden, Nina (2018). *Yellow Kayak*. Simon & Schuster/Paula Wiseman Books.
4. Dr. Seuss (1972). *Marvin K. Mooney Will You Please Go Now!* Random House.
5. Emberley, Rebecca (1990). *Taking a Walk*. Scholastic.
6. Lepora, Nathan (2018). *DK findout! Robots*. DK Children.

Websites for Students

1. For more on classroom rules, go to www.harrykindergartenmusic.com/song/204
2. For more on rhymes and poems, go to <http://www.starfall.com>
3. For more on science experiments, go to <http://www.sciencebuddies.org>
4. For more on safety signs, go to <http://www.kidshealth.org>
5. For more on poems, go to <http://www.storyit.com/Classics/JustPoems/>
6. For more on fruits and vegetables, go to <http://www.healthykids.nsw.gov.au/kids-teens/eat-morefruit-and-vegie-kids.aspx>
7. For more on birthdays, go to www.learnenglishkids.britishcouncil.org/en/your-turn/birthdays
8. For more on stories, go to <http://www.kidsgen.com/stories/>
9. For more on North America, go to <http://www.easyscienceforkids.com/all-about-northamerica/>
10. For more on maps, go to www.nationalgeographic.org/education/map-skillselementary-students/

For Teachers

1. Belgrove, Teresa (2007). *A collection of children's poems, verses and rhymes*. Trafford Publishing.
2. Biggs, Matthew (2009). *Vegetables, Herbs and Fruit: An Illustrated Encyclopedia*. Firefly Books.
3. Bohart, Holly & Benson, Heather (2016). *Spotlight on Young Children: Teaching and Learning in the Primary Grades*. National Association for the Education of Young Children.
4. Chancellor, Deborah (2007). *Maps and Mapping (Science Kids)*. Kingfisher.
5. Copple, Carol (2014). *Developmentally Appropriate Practice: Focus on Children in First, Second, and Third Grades*. National Association for the Education of Young Children.
6. Díaz Barriga Arceo, Frida & Hernández R. Gerardo (2000). *Estrategias docentes para un aprendizaje significativo: una interpretación Constructivista*. McGraw-Hill.
7. Harmer, Jeremy (2015). *The Practice of English Language Teaching (Longman Handbooks for Language Teaching)*. Pearson Longman.
8. Jolibert, Josette & Jacob, Jeannette, coord. (2003). *Interrogar y producir textos auténticos: Vivencias en el aula*. Ediciones LOM.
9. Klinger, Cinthia & Vadillo, Guadalupe (2000). *Psicología cognitiva. Estrategias en la práctica docente*. McGraw-Hill.
10. Lightbown, Patsy M. & Spada, Nina (2006). *How Languages Are Learned*. Oxford University Press.
11. Liantas, John (ed.) (2018). *The TESOL Encyclopedia of English Language Teaching*. Wiley-Blackwell.
12. Maley, Alan, coord. (1999). *Resource Books for Teachers: Projects with Young Learners*. New York.
13. Pérez Esteve, P. & Zayas, F. (2007). *Competencias en Comunicación Lingüística*. Alianza Editorial.
14. Pinter, Annamaria (2006). *Teaching Young Language Learners*. Oxford University Press.
15. Richards, Jack C. (2017). *Curriculum Development in Language Teaching*. Cambridge University Press.
16. Scieszka, Jon (2009). *Truckery Rhymes*. Simon & Schuster.
17. Vale, David & Feunten, Anne (1995). *Teaching Children English: A Course for Teachers of English to Children*. Cambridge University Press.
18. Watkins, Peter (2018). *Teaching and Developing Reading Skills: Cambridge Handbooks for Language Teachers*. Cambridge University Press.
19. Zabala, A. & Arnau, L. (2007). *11 ideas clave: Cómo aprender y enseñar competencias*. Graó Editorial.

Websites for Teachers

1. To learn about methodology
<http://www.teachingenglish.org.uk/>
2. For ideas on games and fun activities
<http://www.funandgames.org/>
3. For lots of teaching ideas
<http://www2.scholastic.com/browse/home.jsp>
4. For competency
<http://www.oei.es/noticias/spip.php?article2307>

Glossary

Conveying meaning: making sure that students understand the significance of the vocabulary and structures they are learning. Meaning can be conveyed through mime, simple drawings on the board or showing learners real objects.

Elicitation: having students provide information (vocabulary) to the teacher rather than the teacher providing it to the students. To elicit the word "cow," for example, the teacher could draw a picture of the cow on the board and ask students for its name, or act like a cow and say "moo" and ask students to name the animal being acted out. Elicitation develops a learner-centered dynamic, makes learning memorable because students link new ideas with information they already have, and helps to produce an engaging environment.

Miming: using body language to convey the meaning of words and phrases. Acting out a verb or posing as the object designated by a noun are two examples of miming. (Note that in miming, exaggerated movements will make the activity more stimulating and the meaning clearer.) Miming is a way of conveying meaning; see "conveying meaning," above.

Monitoring: watching and listening without interfering directly, while students are involved in an activity. Note that in monitoring, there are times when a brief intervention is appropriate: to clarify instructions, or to help students move forward by prompting them with simple questions. Monitoring is an excellent way of finding out what problems the students are having so as to be able to give them feedback.

Realia: real objects used in the classroom. The main advantage of using realia is that it can make the learning experience more memorable. An example of realia is flowers or fruit that are brought into the classroom when related vocabulary is being taught. A great advantage of realia is that students are able to touch, smell and see the objects at the same time as they are hearing the new words.

Self-evaluation: having students reflect on and judge their own progress. Students can be encouraged into self-evaluation through techniques such as asking them to draw a happy face next to what they feel confident about and a sad face next to what they are unsure of. Self-evaluation allows students to discover what they know, what they can do, what they need, and what they would like to explore.



Richmond

www.richmond.com.mx

Distribución gratuita • Prohibida su venta

Yes, we can!

2

Yes, We Can! is designed for the twenty-first century elementary school teacher, using a child-friendly approach and modern methodology. The course is made up of four components that interact fully for optimum results:

- Activity Book
- Fiction and Nonfiction Big Books
- CD (Digital Component)
 - Audio Program & CD Track List
 - Posters
- Teacher's Guide

All in all, *Yes, We Can!* is a complete and balanced course that young learners and their teachers will enjoy. *Yes, We Can!* helps learners learn and teachers teach. It's that simple!



SEP

SECRETARÍA DE
EDUCACIÓN PÚBLICA



PRONI
PROGRAMA NACIONAL
DE INGLÉS

ISBN 978-607-06-1545-0



9 786070 615450