



3rd Grade
Unit: 3

Classroom Language

Look, Read and Label.

Example:

Word Bank

1. ~~Close the door.~~
2. Come in.
3. Open the window.
4. Listen.
5. Clean the board.
6. Be quiet.

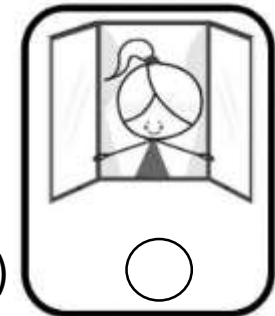
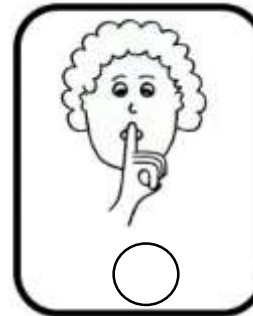
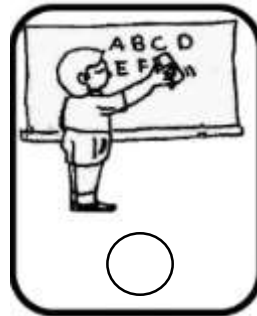
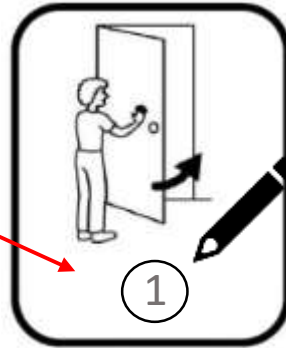

Answer Key: 2. c, 3. f, 4. b, 5. d, 6. e.



Look, Find, Circle and Write.

Word Bank



~~DOOR~~ - CLEAN - BOARD - LISTEN - TAKE - TITLE
NOTEBOOK - MATERIALS - INSTRUCTIVE - INSTRUCTIONS

B	W	I	V	L	S	E	A	T	V	J	V	P	S	G
Q	Y	Z	I	O	V	Z	X	Z	U	T	I	T	L	E
J	J	N	Q	N	M	J	V	D	P	K	G	C	S	Q
W	Y	I	S	P	R	W	F	I	Q	D	A	O	A	G
I	I	I	N	S	T	R	U	C	T	I	V	E	W	G
N	I	R	S	S	C	Z	R	P	K	W	N	H	U	U
O	F	P	M	A	T	E	R	I	A	L	S	D	R	D
T	T	A	K	E	U	R	H	U	DOOR	E	E			
E	D	G	N	V	C	Y	U	X	P	P	Z	M	C	C
B	N	L	Y	R	L	Y	E	C	B	O	A	R	D	R
O	X	I	O	B	W	D	A	C	T	J	I	H	T	C
O	K	S	S	S	V	E	D	A	G	I	K	S	B	B
K	F	T	T	Z	J	R	L	S	P	V	O	K	W	E
N	E	E	F	R	C	Z	G	L	E	V	O	N	A	I
H	P	N	F	F	C	L	E	A	N	Z	A	X	S	B

Example:

1.-	DOOR	
2.-	_____	
3.-	_____	
4.-	_____	
5.-	_____	
6.-	_____	
7.-	_____	
8.-	_____	
9.-	_____	
10.-	_____	

Parts of an Instructive

 Look,  Read,  Count / Number.

Example: 1. 

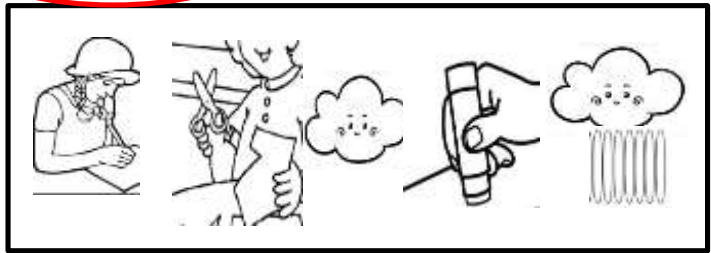

3.

First
Draw and cut out the shape of cloud from the white cardstock paper.

Second
Glue the rainbow-colored sticks on one side of the cloud cutting. Let it dry for some time.

Third
Glue the wiggle eyes on the other side of the cloud and draw the mouth and nose with a black pen.

2.

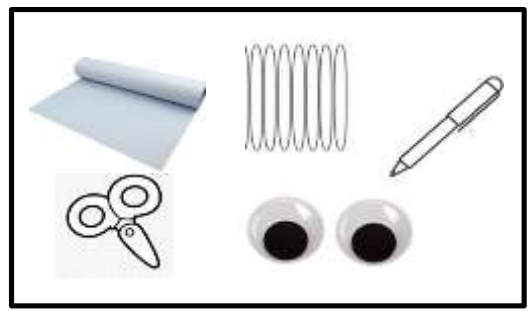



Word Bank

- a) Title
- b) Materials
- c) Instructions
- d) ~~Pictures~~

4.



What is It?

 Look,  Read and  Match/Connect.

Example:

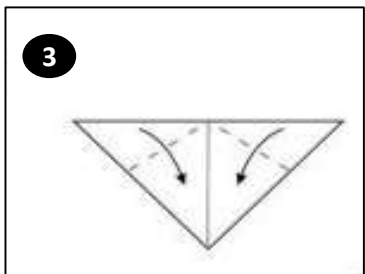
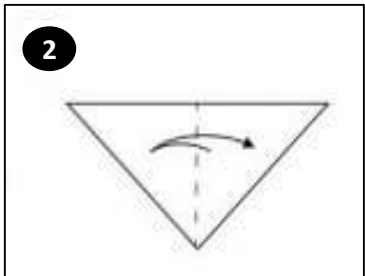
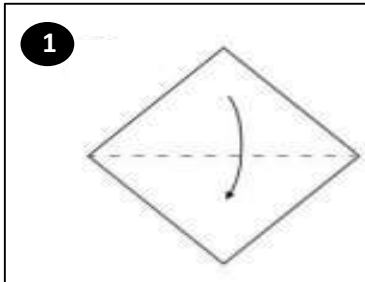

a).- Fold the paper to make a triangle.

b).- Draw the face.

c).- Make the ears by folding the corners of the triangle down.

d).- Fold the dotted line to make the snout.

e).- You already have the dog .

f).- Fold in a half to make a crease.

