

# PROGRAMA NACIONAL DE INGLÉS

## Cuaderno de Actividades



 Look, 
  Write and 
  Read.

A	B	C	D	E	F	G	H	I	J	K	L	M	N	O	P	Q	R	S	T	U	V	W	X	Y	Z
1	2	3	4	5	6	7	8	9	10	11	12	13	14	15	16	17	18	19	20	21	22	23	24	25	26

Example:

1. 

S	A	L	S	A
19	1	12	19	1

2.

13	1	18	9	1	3	8	9

3.

18	15	3	11

4.

13	21	19	9	3

5.

3	12	1	19	19	9	3

6.

16	15	16

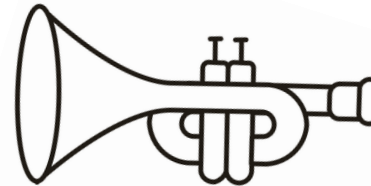
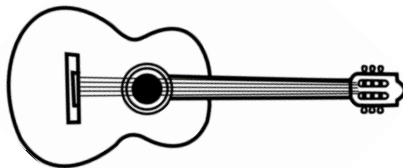

# The Hidden Secret Message



Read ,



Think and



Write .

**Note:** You can use the answer options more than once.

**Example:**

W	A genre.
	It originated in the U.S.A. around 1940.
	Composed by a large group of musicians.
	Play several instruments.
	It is a mix of cha cha cha and mambo.
	It was composed in the years 1750 and 1820.
	A short name for popular.
	Play electric guitar and drums.

## Answer Bank

<b>o.</b> Classic
<del><b>w.</b> It is a category</del>
<b>l.</b> Mariachi
<b>n.</b> Pop
<b>e.</b> Rock
<b>d.</b> Salsa

Write your secret message: \_\_\_\_\_.

Look, Read, Cut, Classify and Glue.

Example:

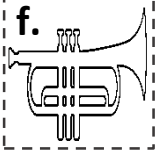
<p>1. Brass</p> <p>f.</p> 	<p>2. Keyboard</p>	<p>3. Percussion</p>
<p>4. String</p>		<p>5. Woodwind</p>





Look,



Write and



Color.

Example:

## Word Bank

~~drum~~ guitar maracas piano trumpet violin



1. drum



2. \_\_\_\_\_



3. \_\_\_\_\_

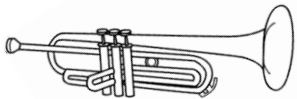

4. \_\_\_\_\_



5. \_\_\_\_\_



6. \_\_\_\_\_



Look ,



Write and



Color .

Example:

1. [ ] [ ] [ ]

2. [ ] [ ] [ ]

3. [ ] [ ] [ ] [ ] [ ] [ ] [ ] [ ] [ ] [ ]

4. [ ] [ ] [ ]

5. [ ] [ ] [ ]

6. [ ] [ ] [ ] [ ] [ ] [ ] [ ] [ ] [ ] [ ]

7. x y l o p h o n e

8. [ ] [ ] [ ] [ ] [ ]

Across →

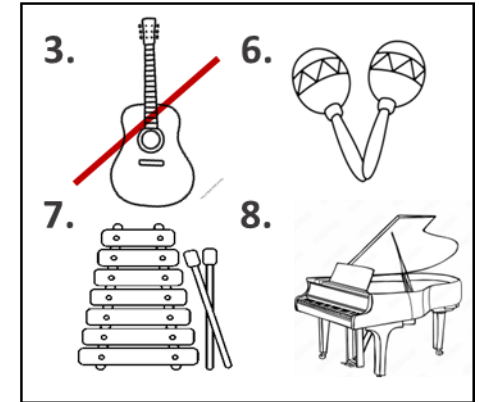



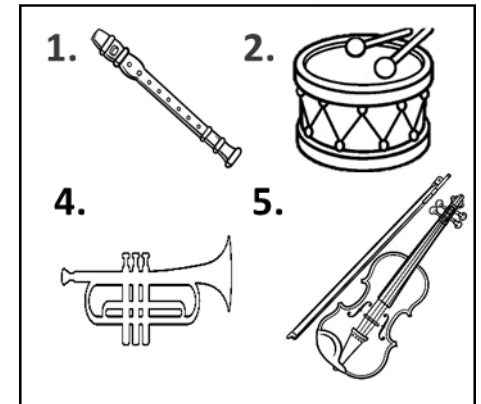

Down ↓



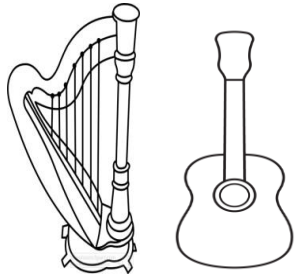



# What family do I belong to?

Look, Cut, Classify and Glue.

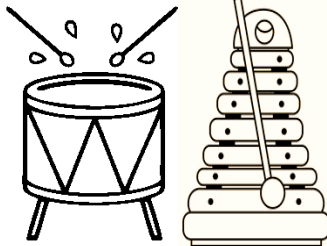
1.   

2.   

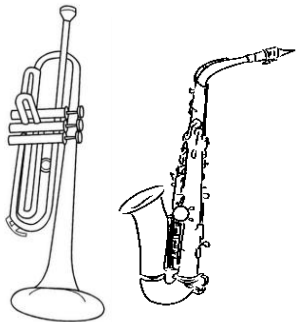
3.   

4.   



Brass      Percussion      Woodwind (Wind)      Strings

# Where is my family?





Look,



Read and

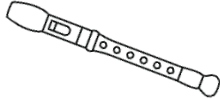
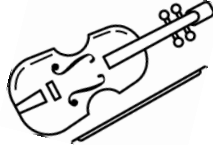

Underline.

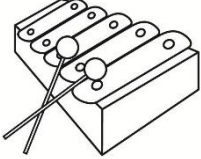
<p><b>1.</b></p>  <p><b>a.</b> String family. <b>b.</b> Wind family. <b>c.</b> Percussion family.</p>	<p><b>2.</b></p>  <p><b>a.</b> String family. <b>b.</b> Wind family. <b>c.</b> Percussion family.</p>	<p><b>3.</b></p>  <p><b>a.</b> String family. <b>b.</b> Wind family. <b>c.</b> Percussion family.</p>
<p><b>4.</b></p>  <p><b>a.</b> String family. <b>b.</b> Wind family. <b>c.</b> Percussion family.</p>	<p><b>5.</b></p>  <p><b>a.</b> String family. <b>b.</b> Wind family. <b>c.</b> Percussion family.</p>	<p><b>6.</b></p>  <p><b>a.</b> String family. <b>b.</b> Wind family. <b>c.</b> Percussion family.</p>





Read,



Think and



Complete.

**Example:**

## Word Bank

Brass

~~Percussion~~

percussion

Strings

wind

a. Percussion instruments make a sound when they are hit, shaken, or rubbed.

b. The flute and the clarinet are examples of \_\_\_\_\_ instruments.

c. \_\_\_\_\_ instruments are made of brass or metal and make a sound when air is blown inside.

d. The xylophone and drums are examples of \_\_\_\_\_ instruments.

e. \_\_\_\_\_ instruments make sounds with the vibration created by their strings.

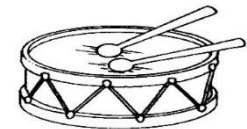

# Which instruments...?



Read,



Think and



Complete.

a. I prefer \_\_\_\_\_ maracas over there.

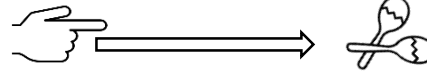

b. \_\_\_\_\_ trumpets are expensive.

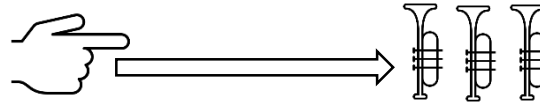

c. \_\_\_\_\_ is a new violin.

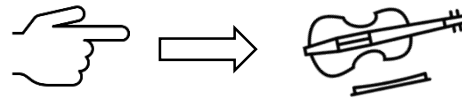

d. \_\_\_\_\_ are my favorite guitars.

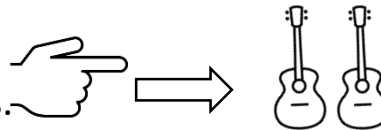

e. \_\_\_\_\_ harp is a good one.

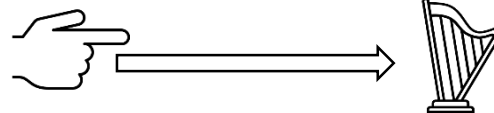

## Word Bank

- That
- These
- This
- Those
- those



Read ,



Think and



Circle .



1. I prefer **that/those** harp.

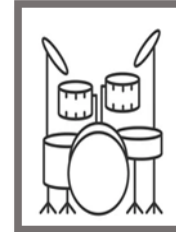

2. **These/that** are some modern drums.

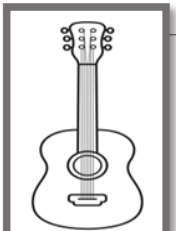

3. **This/these** guitar here belongs to my dad.

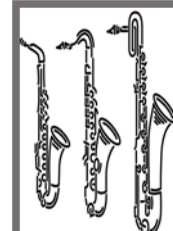

4. **These/this** saxophones are golden.

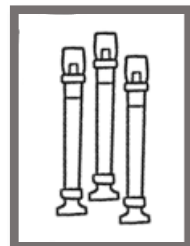

5. **Those/that** flutes over there are expensive.

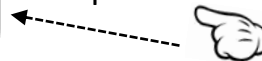



Read,



Complete and



Color.

## Word Bank

- the biggest brass instrument
- is a string instrument
- a woodwind instrument
- has up to 39 strings.
- comes from Africa
- has white and black keys

1. The guitar \_\_\_\_\_.



2. The keyboard \_\_\_\_\_.



3. The drum \_\_\_\_\_.

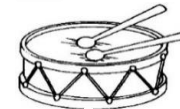

4. The clarinet is \_\_\_\_\_.



5. The tuba is \_\_\_\_\_.

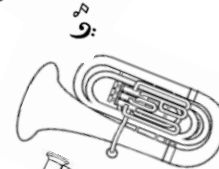

6. The harp \_\_\_\_\_.



# Instrument Classification

 Look,  Think,  Draw and  Color.

